

# Advanced Features of InfraTec Pyroelectric Detectors

## 4. Basics and Application of Variable Color Products

The key element of InfraTec's variable color products is a silicon micro machined tunable narrow bandpass filter, which is fully integrated inside the detector housing. Applying a control voltage to the filter allows it to freely select the wavelength within a certain spectral range or to sequentially measure a continuous spectrum. This design is very different from detectors with fixed filter characteristics and enables the customer to realize a low resolving and low cost spectrometer.

The variable color product group includes the **LFP-3041L-337** and **LFP-3950L-337** which differ in the wavelength range they each cover. The pyroelectric detector used is similar to the standard **LME-337** device.

### 4.1. Fabry-Perot filter (FPF)

The filter-detector assembly (see Figure 1) is based on the well-known Fabry-Perot Interferometer (FPI). Two flat and partially transmitting mirrors with reflectance  $R$  are arranged in parallel at a distance  $d$ , forming an optical gap. Multiple-beam interference is created inside the gap and thus only radiation can be transmitted, which satisfies the resonance condition according to equation (1).

One of the mirrors is suspended by springs so that the distance  $d$  can be decreased by applying a control voltage. As the resonance condition changes so does the wavelength of the transmitted radiation.

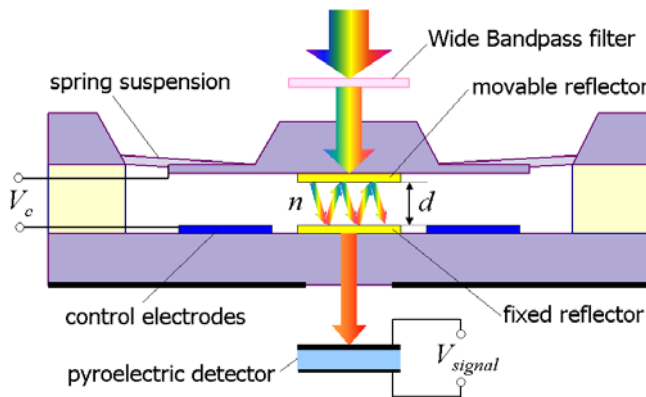

$$\lambda_m = \frac{2 n d \cos \beta}{m} \quad (1)$$

- $n$  refractive index inside the gap
- $\beta$  angle of incidence ( $\beta = 0$  in fig.1)
- $m$  interference order
- $d$  modulating distance

Fig. 1: Configuration and operation principle of the FPF with an integrated pyroelectric detector

The **transmittance spectrum**  $T(\lambda)$  of the FPF (see Figure 2) is described by the Airy-Function. Given that  $n = 1$  (air inside the gap) and  $\beta = 0$  (vertical incidence), this results in:

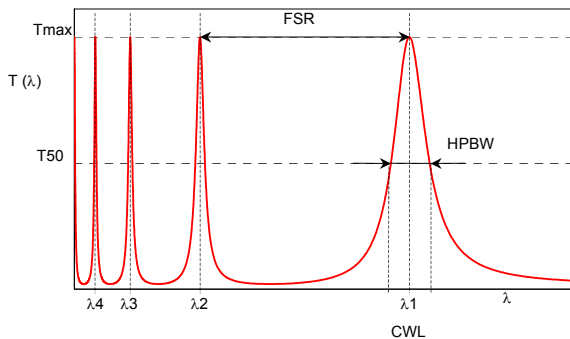

$$T(\lambda) = \frac{T_{\max}}{1 + F \sin^2(2\pi d/\lambda)} \quad (2)$$

with the F-value:

$$F = \frac{4R}{(1 - R)^2} \quad (3)$$

Fig. 2: Transmittance spectrum of a FPF

# Advanced Features of InfraTec Pyroelectric Detectors

The characteristic parameters of a FPF can be derived from the previous equations. In our case, the first interference order is used ( $m = 1$ ), while the higher orders are blocked by means of an additional bandpass filter.

**The center wavelength (CWL)** of the filter corresponds to the resonant wavelength in theory. In practice the **CWL** is measured as the mean value of the two **half-power-points ( $T_{50}$ )**.

The **half-power bandwidth (HPBW)** is the decisive factor for the spectral resolution:

$$HPBW = 2d \left( \frac{1-R}{\pi\sqrt{R}} \right) \quad (4)$$

The spectral distance of two adjacent interference peaks limits the maximum usable tuning range. This is referred to as the **free spectral range (FSR)**.

The ratio of the tuning range to the bandwidth (in the frequency or wavenumber domain) is given as the **Finesse ( $\tilde{F}_R$ )**, which is the figure of merit of a FPF:

$$\tilde{F}_R = \frac{FSR}{HPBW} = \frac{\pi\sqrt{R}}{1-R} = \pi \frac{\sqrt{F}}{2} \quad (5)$$

## 4.2. Optical Considerations

In the real world there are some practical constraints, so it's necessary to complete the previous statements and equations:

The mirrors of the FPI are made from dielectric layer stacks (Bragg reflectors). This limits the width of the reflective band and thus the usable spectral tuning range to about  $1.3\mu\text{m}$ . Bragg reflectors have a distinct phase shift, which actually has to be considered in the equations stated above. This causes an increase of the mechanical adjustment travel  $\Delta d$ :

$$\Delta CWL = k \cdot 2\Delta d \quad (k < 1 \text{ phase correction}) \quad (6)$$

An inclined but collimated beam results in a negative drift of the CWL (see figure 3 left). The most common case is an uncollimated beam with a certain angle of divergence and intensity profile. The resulting transmittance spectrum can be seen as the superposition of collimated ray-beams with different angles of incidence and intensities. The superimposed spectrum has a broader HPBW and the CWL at slightly lower wavelengths (see figure 3 right).

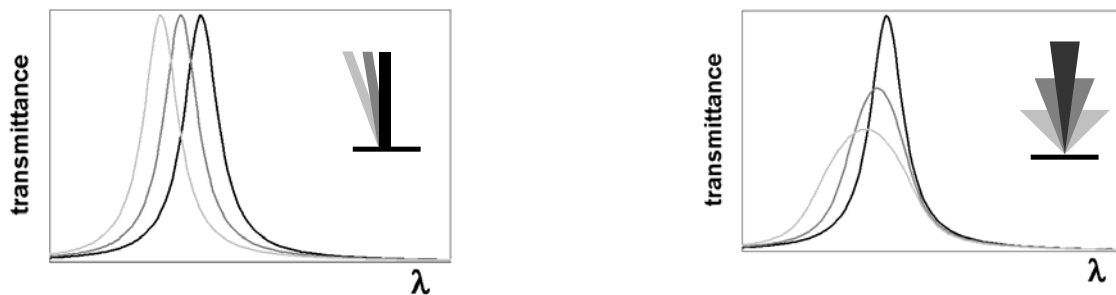

Fig. 3: Influence of angle shift and divergence angle on bandwidth and peak transmittance of a FPF

# Advanced Features of InfraTec Pyroelectric Detectors

Beam divergence can be minimized by using a light source with collimated output or by means of an additional prefixed aperture (see figure 4 left). If the desire is to maximize the optical throughput, then focusing optics can be used, but larger divergence angles will be a side effect (see figure 4 right).

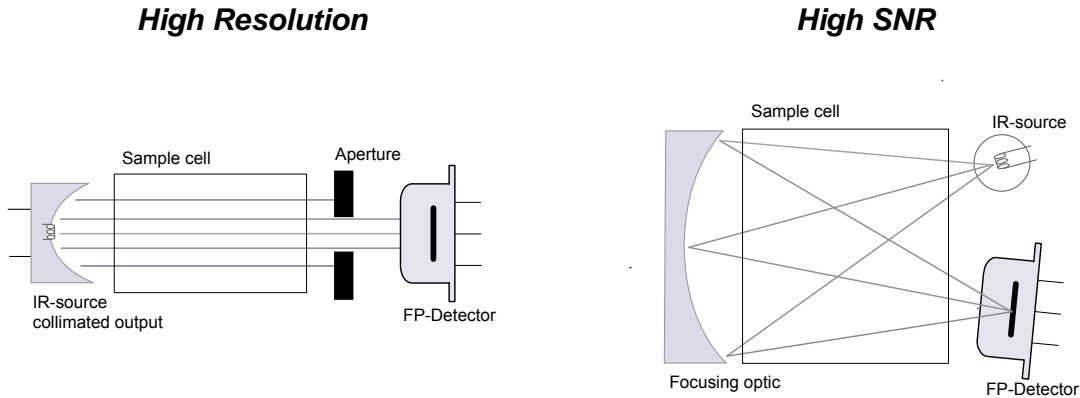

Fig. 4: Possible optimizations for the optical design of a microspectrometer with FPF detector

**left set up:** corresponds with an illumination by a parallel beam; **right set up:** corresponds with a high angle of incidence (AOI)

The performance of such a system strongly depends on the optical conditions. A compromise between spectral resolution and **signal-to-noise ratio (SNR)** for the particular application needs to be found. This principle is in fact valid for all spectrometric applications. Figure 5 shows the correlation of the achievable SNR with a given spectral resolution, measured with two tested measurement set ups according to figure 4. Please note that a parallel beam  $\varnothing 1\text{mm}$  offers the highest spectral resolution but only 3% of the intensity and thus the resulting low detector signal voltage compared to an illumination using f/1.4 optics.

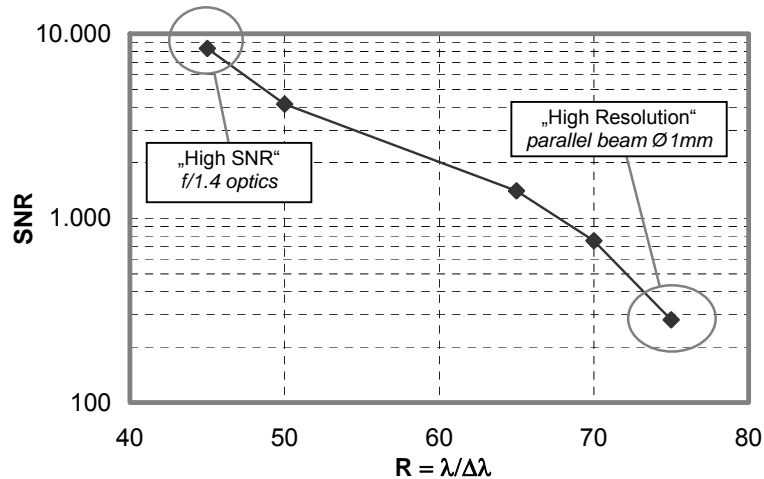

Fig. 5: Measurements of the SNR vs. spectral resolution

LFP-3041-337 with a modulated IR source at 10Hz, **left end point:** Illumination at high angle of incidence (AOI) using f/1.4 optics **right end point:** Illumination with a parallel beam  $\varnothing 1\text{mm}$

# Advanced Features of InfraTec Pyroelectric Detectors

Tuning the CWL of the FPF results in a variation of the HPBW and the peak transmission within certain limits, too. The additionally implemented broad band pass and the pyroelectric detector element also show some spectral characteristics. The spectral response of the detector is therefore a superposition of different fractions, but has to be considered as a whole in the application. It is stated as the relative spectral response, referring to a “black” reference detector with a flat spectral response (see figure 6).

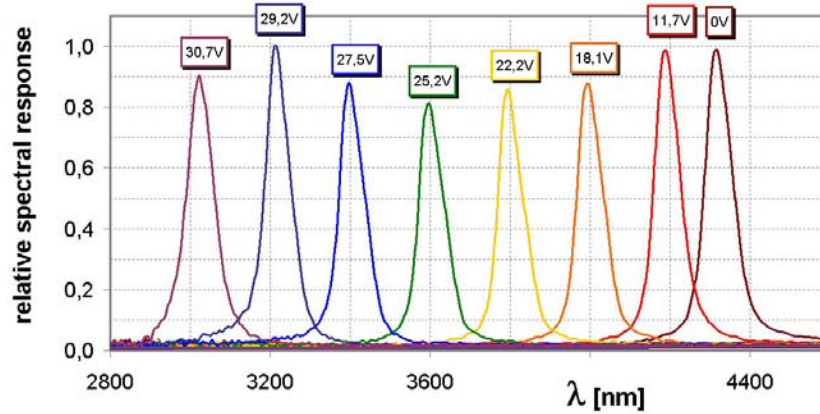

Fig. 6: Relative spectral response of a FPF detector LFP-3041L-337 at several tuning voltages

### 4.3. Filter operation

The filter is activated electrostatically. The driving electrode ( $V_{c+}$ ) is arranged at the fixed reflector carrier, the movable reflector carrier acts as an electrode with the fixed reference potential  $V_{cref}$  (see figure 8). Applying a tuning voltage  $V_c = V_{c+} - V_{cref}$  results in an electrostatic force  $F_{el}$  decreasing the electrode gap  $d_{el}$ .

$$F_{el} = \frac{\epsilon_0 A_{el} V_c^2}{2d_{el}^2} \quad (7)$$

With this the drive capacity is increased from  $\approx 50 pF$  in passive state ( $V_c=0V$ ) to  $\approx 65 pF$  at maximum modulation. Additionally a parasitic parallel capacity of 1nF needs to be considered. In the case of steady state, a typical non-linear characteristic curve is received (see figure 7).

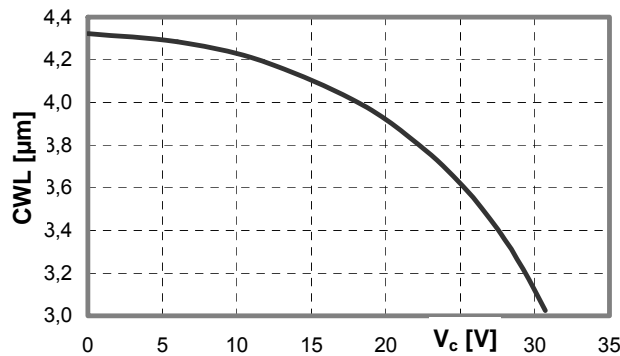

Fig. 7: Typical steady-state control characteristic for LFP-3041L-337

# Advanced Features of InfraTec Pyroelectric Detectors

The polarity of the control voltage needs to be maintained, even as in equation (7) this doesn't seem to be necessary.

The circuit points *Shield*, *Substrate* and  $V_{cref}$  should be on the same stabilized, low-impedance potential. Spikes, a ripple voltage and other interfering signals at these circuit points can cause cross talk to the pyroelectric detector components by parasitic capacitances.

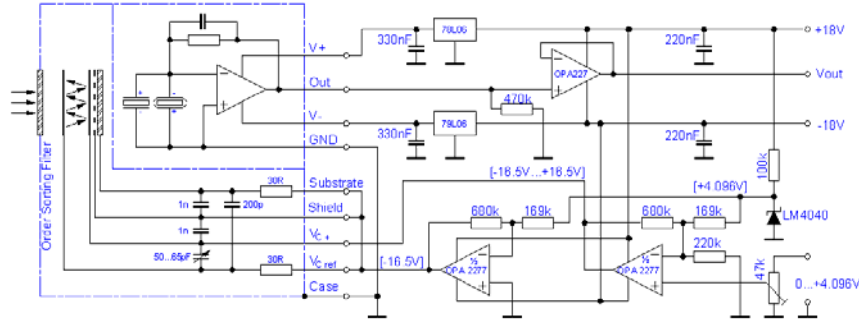

Fig. 8: Example of circuitry for detector and filter operation ( $\pm 18V$  bipolar supply)

The movable reflector of the FPI is a mass-spring-system, which is progressively damped by the air cushion in the gap. The non linear fraction in equation (7) effects a decreasing stiffness of the whole system with increasing modulation, i.e. smaller gap. This behavior leads to several effects:

The filter exhibits an acceleration sensitivity but vibrations will be damped due to the mechanical low pass characteristic. In steady state a dependence of the CWL on the position related to the gravitation field is observed (see Figure 9). Both effects are dependent on the actual mirror position.

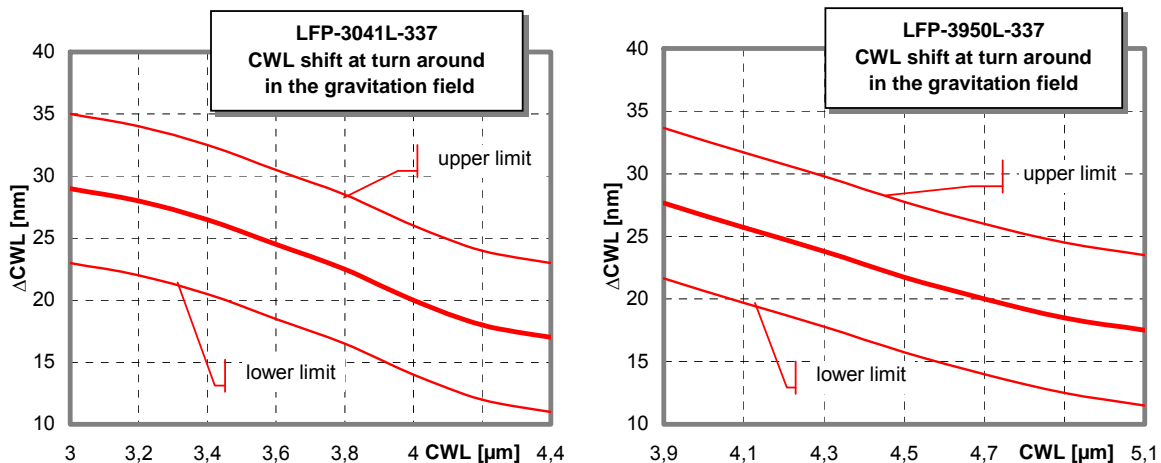

Fig. 9 Position dependency of the CWL, typical values and tolerance zones of LFP-3041L-337 (left) and LFP-3950L-337 (right)

- The filter shows a stability limit at the so-called pull-in point. This should never be exceeded during operation, otherwise the filter could be damaged. As a guideline for steady state can be given: Don't exceed the control voltage for maximum modulation (e.g. CWL=3000nm for LFP3041L-337) for more than 0.5 volts. This is an individual value for each device.

# Advanced Features of InfraTec Pyroelectric Detectors

- The transient response of the filter is non-linear. For shorter wavelengths the system reacts slower, because the total stiffness of the system is low and the air damping is high. The stated settling time (see figure 10) is defined as the necessary time to achieve the final value of the CWL with a tolerance of  $\pm 1$  nm for a control voltage step.

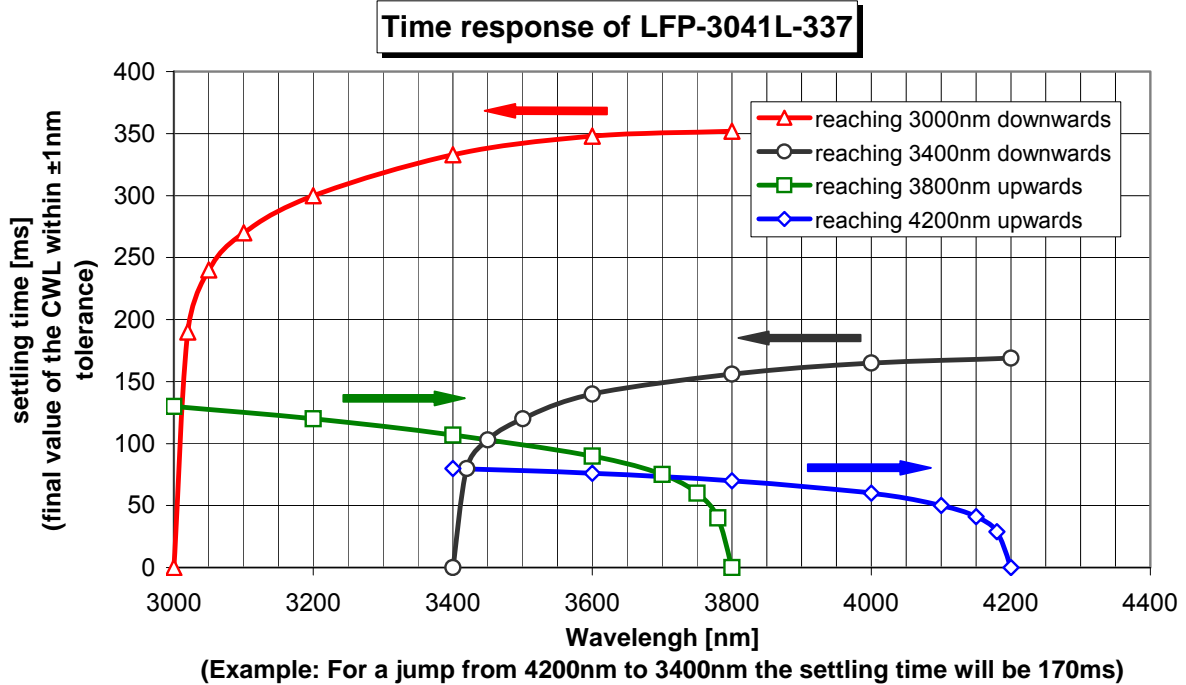

Fig. 10: Transient response for LFP-3041L-337, typical values

- The FP filter also shows a significant temperature dependency. As a temperature change mainly results in a mechanical detuning of the filter, the correlation between HPBW and CWL remains unchanged.

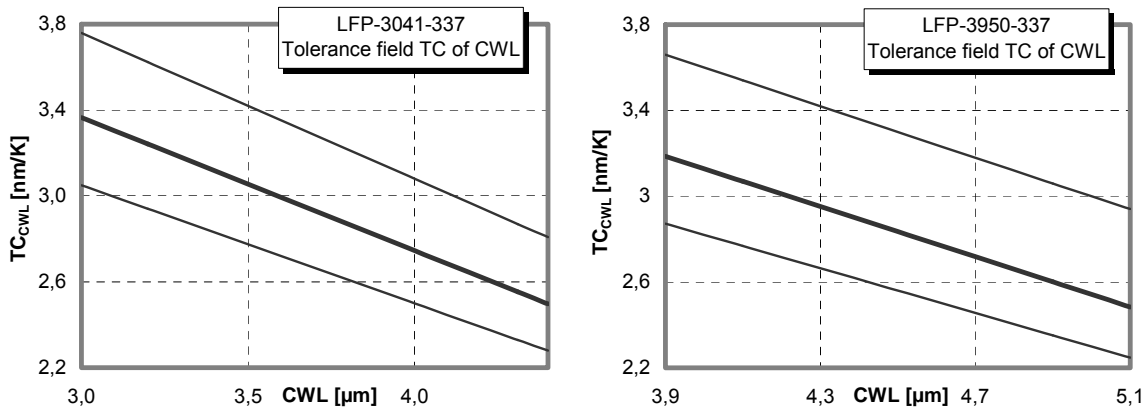

Fig. 11: Temperature coefficients of the CWL, typical values and tolerances for LFP-3041L-337 (left) and LFP-3950L-337 (right)

---

# Advanced Features of InfraTec Pyroelectric Detectors

---

## 4.4. Operation modes and measurement methods

The capabilities of FPF (so called variable color) detectors are numerous. Depending on the measurement task and operation mode, different advantages compared to conventional single or multi channel detectors with fixed NBP filters can be found.

Hereafter three different operation modes will be explained in detail:

### Sequence of channels

In the most simple case several fixed detector channels shall be substituted by a tunable detector. The filter is sequentially adjusted to the individual spectral channels. Beside the obvious advantage of the flexibility and expandability in the channel choice (in the region (3...5)  $\mu\text{m}$ ) additional advantages may be achieved:

- Simple multi channel detectors have separated apertures, which yield to the well known issues regarding non-uniform illumination, long-term stability, source drifting, pollution, etc. The variable color detectors don't show these problems due to their principal design and singular light path.
- Detectors with an internal beamsplitter also have a common aperture, but each channel is getting only a fraction of the whole radiant power. Applying the sequential measurement we can always use the whole incident radiant power. For four different channels and comparable conditions regarding aperture size and filter bandwidth theoretically a duplication of the SNR can be reached.

### Step scan

The method described above can still be expanded in such a way that continuous spectra can be obtained. The required acquisition time for the mapping of a spectrum depends on the following facts:

1. Number of measuring points (wavelength range, step size):  
To get a continuous spectrum it must be scanned at minimum with a step size which corresponds to the half filter bandwidth (sampling theorem). Moderate oversampling can be useful. The reasonable step size is in the range (10...50) nm.
2. Recordings of the measuring points (modulation frequency, integration time):  
These parameters define the SNR. Beside the detector properties and the applied analysis methods, the radiant power, modulation depth of the IR source and the design of the measuring section are crucial.

Settling time of the filter:

The actual settling time of the filter depends on the wavelength as described earlier. It should therefore be implemented variably to achieve an optimum of speed.

---

# Advanced Features of InfraTec Pyroelectric Detectors

---

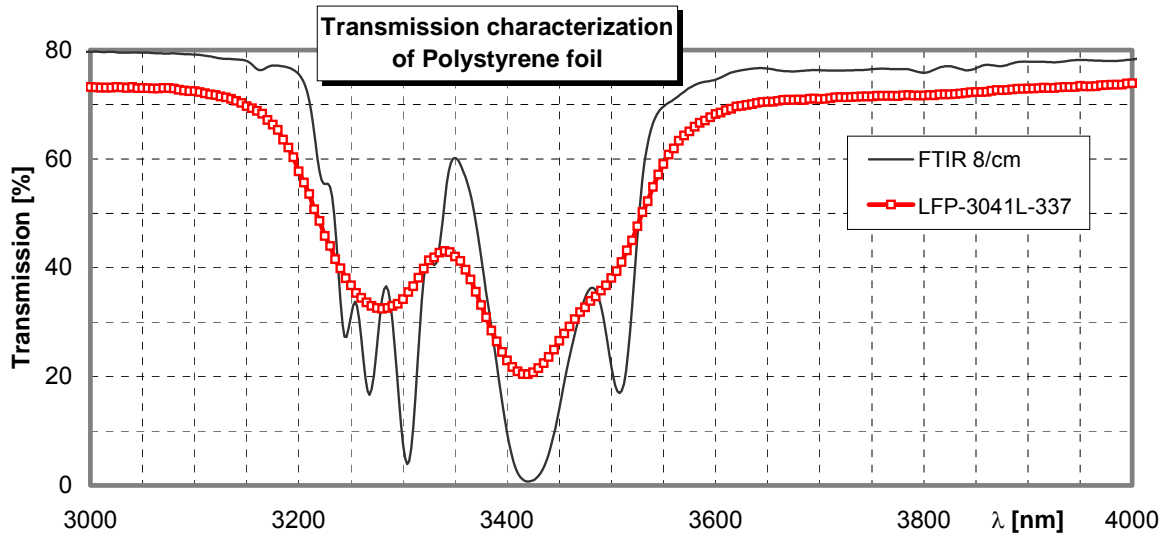

Fig. 12: Measurement example for the step scan mode (Polystyrene foil)  
LFP-3041L-337: spectral resolution  $R=65$ ;  $SNR \approx 1000:1$ ; 100 data points; acquisition time 10s

## Continuous scan

By using a pyroelectric detector only modulated radiation can be analyzed. Normally this is realized by mechanical chopping or electrical modulation of the IR source. If the filter is however continuously scanned the spectral information can be used directly for the modulation. The filter is actuated dynamically in this case.

This particular operation mode has principally the potential to accelerate the recordings of spectra remarkably. The earlier mentioned non-linear effects during dynamic operation however need to be considered separately. In most cases it is not correct to consider the filter as a linear system with low pass behavior even in a limited operation range.

Two basic approaches are possible for a dynamic operation:

- Presetting of voltage characteristics  $V_c(t)$  for filter modulation (sinusoidal, ramp or similar...) and
  - Detection of the resulting characteristics of the CWL by an adequate calibration for example with wavelength standards (e. g. NBP filters) or
  - Evaluation of the detector signal with dedicated software algorithms (chemometric techniques)
- Presetting of a designated progression of the CWL(t) and determination of the compatible voltage characteristic  $V_c(t)$  for example with wavelength standards

---

# Advanced Features of InfraTec Pyroelectric Detectors

---

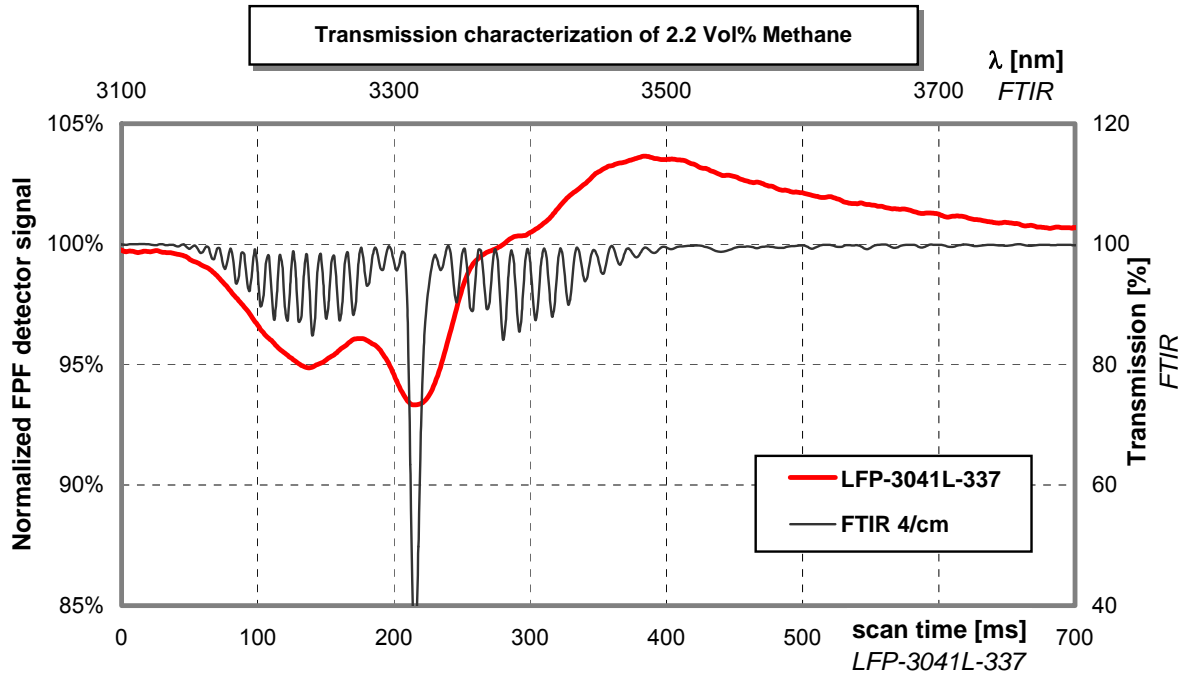

Fig. 13: Measurement example for the continuous scan mode with dynamic filter tuning (Methane)

Figure 13 gives an example for the dynamic operation. The source is working in DC operation, while the filter goes through the desired wavelength range. Except for the DC-portion, the whole spectral information is contained in the generated detector signal. The actuation and analysis has to include both the dynamic properties of the filter and the detector.

## 4.5. Summary

With the extension of our product range by variable color detectors additional technologies are available for our customers. All types of our multi-spectral detectors are complementing one another:

- Conventional dual and quad channel detectors can be used in competitive volume applications
- Our dual and quad channel beamsplitter detectors with one aperture are used as long term stable and very accurate measuring modules for different spectral channels
- Variable color detectors with a high SNR allow a more flexible operation of the analyzer enabling for example the detection of adjoining or overlapping absorption bands. They are also of interest for applications, where more than 4 spectral channels shall be scanned within a short time frame.