

# Advanced Features of InfraTec Pyroelectric Detectors

## 1. Pyroelectric Detectors with JFET source follower or integrated CMOS-OpAmp - A Comparison

In 2003 InfraTec added pyroelectric detectors with integrated CMOS Operational Amplifiers (OpAmp) to our established family of detectors with integrated Junction Field Effect Transistors (JFET). Advancements in analog Silicon based technologies have allowed us to replace the classic JFET design with a more complex amplification circuit for nearly all applications.

Well established JFET detector designs like the LIE-302, LIE-316 and LIM-222 have been enhanced with CMOS OpAmps as in the LME-341, LME-345 and LIM-262.

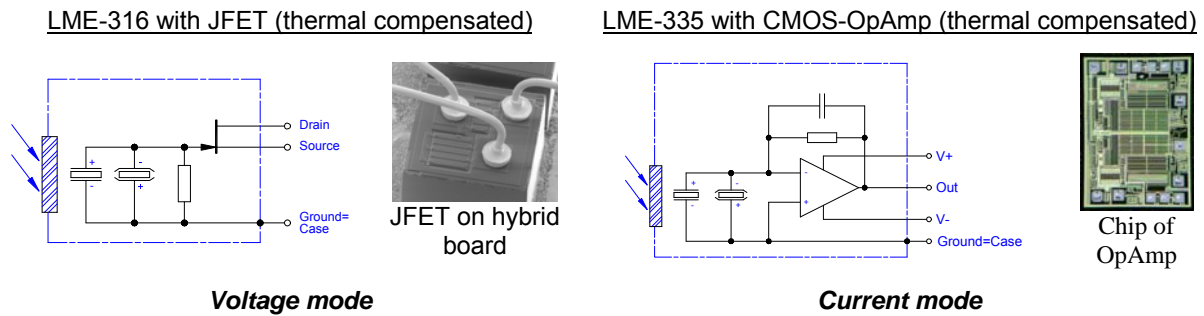

Fig.1: Examples of pyroelectric detectors with JFET (left side) and OpAmp (right side)

Detectors with JFET and OpAmp are distinguished by more than orders of magnitude in signal voltage. The fundamental difference you find is in the analysis of the pyroelectric signal. As a result you will get different frequency responses of signal and noise (response and typical parameters in figure 2).

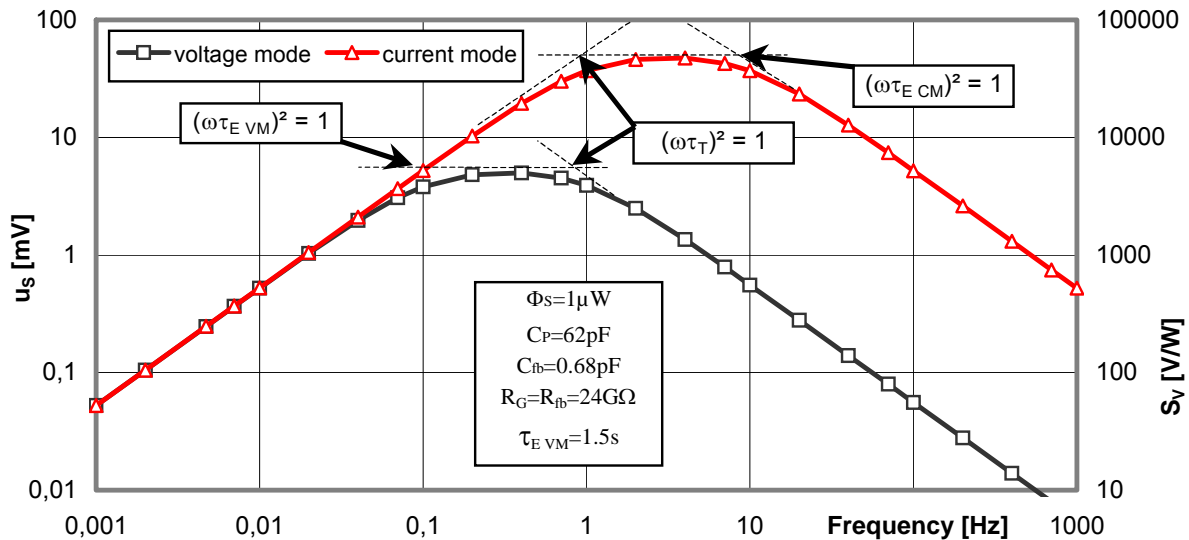

Fig.2: Frequency response of signal voltage  $U_s$  and voltage responsivity  $R_v$  of a pyroelectric detector with 2mmx2mm active sensing element

---

# Advanced Features of InfraTec Pyroelectric Detectors

---

In voltage mode the pyroelectric current, created in the single crystalline  $\text{LiTaO}_3$  chip, charges the electric capacity. The resulting voltage is displayed by a simple Source follower (JFET, gate resistor and external source resistor).

In current mode the generated pyroelectric current is transformed by a Current-Voltage-Converter (OpAmp with feedback components, also named Trans-Impedance-Amplifier TIA). The frequency dependent conversion factor  $I/U$  is determined by the complex feedback components and is typically in the range of 10 ... 200 pA/V. While the thermal time constant  $\tau_T$  (typically 150ms) as a measure of the thermal coupling of the pyroelectric element to its surrounding is effective in both operation modes, the electric time constant  $\tau_E$  is determined by different components. In voltage mode  $\tau_E$  is calculated as a product of pyroelectric chip capacity  $C_P$  and gate resistor  $R_G$  (typically 1.5s). In current mode  $\tau_E$  is only determined by the feedback components  $R_{fb}$  and  $C_{fb}$  (typically 16ms).

## Main differences between pyroelectric detectors with JFET and CMOS-OpAmp

- At common modulation frequencies between 1Hz and 10Hz in gas analysis and flame detection the detector will operate above the thermal and electrical time constant ( $1/f$  behavior of signal). The maximal responsivity is located beyond the normal modulation frequency range. Low-frequency disturbances up to some Millihertz will be transmitted. Detectors need settling times up to some 10 seconds.
- Detectors in current mode are mostly operated between both time constants and resultant cut-on and cut-off frequency. Here the signal voltage is on its highest level and stable over a broad frequency range, possibly over some hundred Hz. Low-frequency disturbances are one magnitude away from the cut-on frequency and will therefore be suppressed 10 times more compared to the voltage mode. The measuring signals are already stable after a few seconds.
- Due to the virtual short circuit of the pyroelectric element in current mode, an antiparallel connected compensation element does not lead to a reduction of signal and detectivity. Furthermore an incomplete illuminated pyroelectric element in current mode does not cause a loss of both signal and detectivity in contrast to the voltage mode.

## Why we are using CMOS-Operational amplifiers?

CMOS technology combines technological and customer demands for a low supply voltage, low power consumption, Rail-to-Rail performance at output and low chip costs. Additionally the completely isolating gate ( $\text{SiO}_2$ ) in the operational amplifier shows a better performance during operation at high temperatures as opposed to the JFET design. The current mode which earlier was only possible to apply in combination with very expensive OpAmps like OPA128 or AD549, can now be applied in applications for gas analysis and flame detection which were previously dominated both technologically and price wise by the JFET.

## Comparison of the modulated output signal for detectors with JFET and OpAmp

The electrical time constant defines the form of the output signal in current and voltage mode. Identical time constants lead to the same signal form in both modes. In current mode we can work with a nearly arbitrary electrical time constant, which is an essential advantage. Therefore short time constants are preferred due to the resulting short settling time.

# Advanced Features of InfraTec Pyroelectric Detectors

Figures 3 to 6 show typical signal characteristics in order with decreasing electrical time constant.

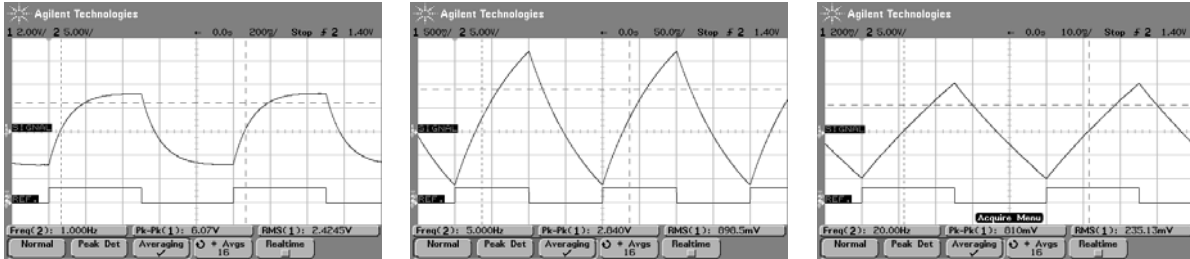

Fig. 3: LME-302 Voltage mode at 1Hz, 5Hz and 20Hz, thermal time constant 150ms, electrical time constant 5s

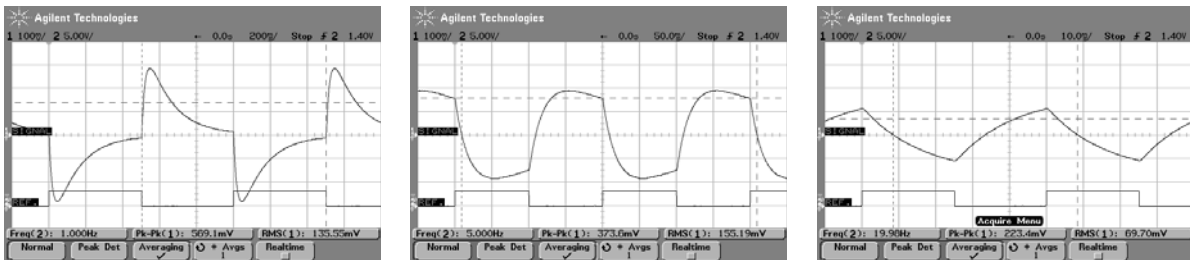

Fig. 4: LME-335 Current mode at 1Hz, 5Hz and 20Hz, thermal time constant 150ms, electrical time constant 20ms

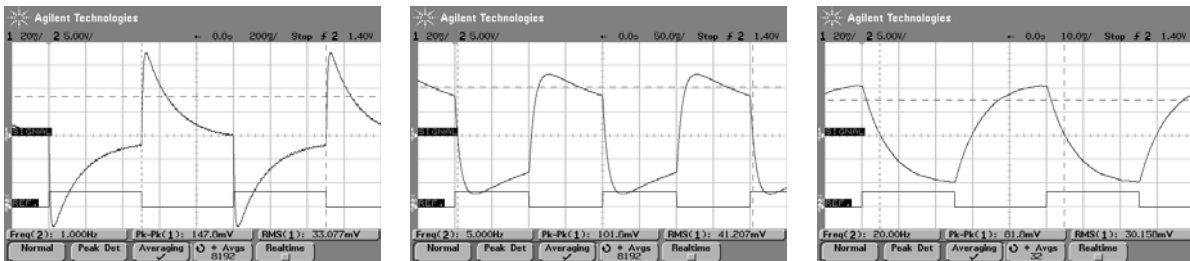

Fig. 5: LME-341 Current mode at 1Hz, 5Hz and 20Hz, thermal time constant 150ms, electrical time constant 5ms

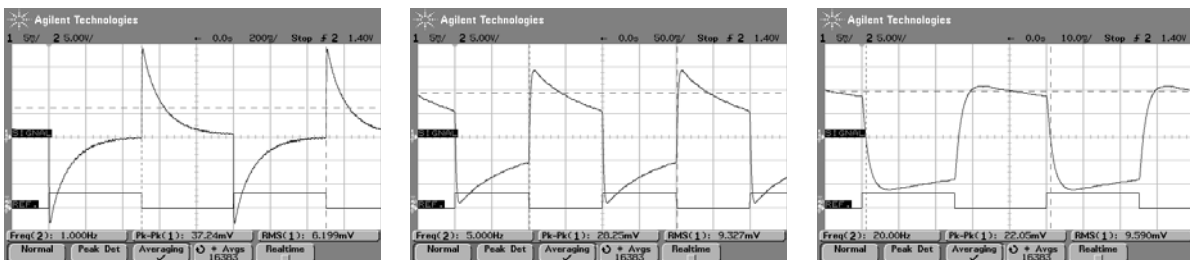

Fig. 6: LME-351 Current mode at 1Hz, 5Hz and 20Hz, thermal time constant 150ms, electrical time constant 1ms

---

# Advanced Features of InfraTec Pyroelectric Detectors

---

## Feedback Resistor Influence to Responsivity (signal), Detectivity (signal-to-noise ratio) and Stability of the operating point for a detector with integrated OpAmp

In accordance with voltage mode detectors the Ohm rating of the integrated resistor leads to opposite detector properties:

- A large resistor results in a high signal and an increased detectivity since the noise only increases the square root of the resistor value. In contrast an amplifier stage after the detector would increase signal and noise by the same ratio.
- A small resistor increases the stability of the DC operating point, therefore a thermal compensation is often not necessary for  $R < 10\text{Gohm}$ .

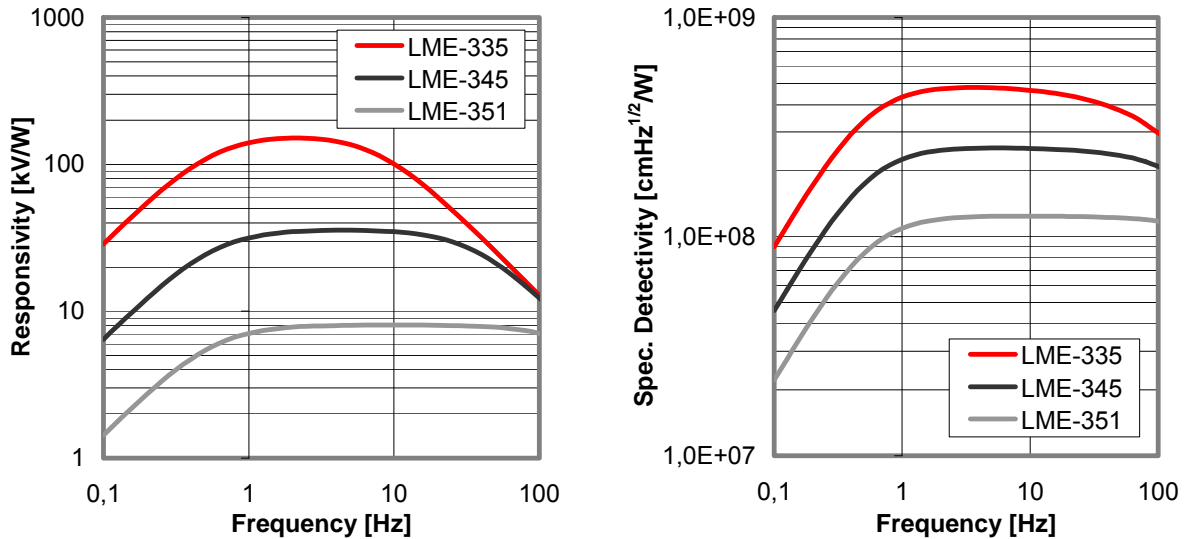

Fig 7: Frequency response of responsivity (signal) and detectivity (signal-to-noise ratio) as a function of the feedback resistor; LME-335 (100GOhm), LME-345 (24Gohm), LME-351 (5GOhm)

## Power supply for InfraTec CMOS OpAmp detectors

We use mainly a split power supply  $\pm 2.2\text{V} \dots \pm 8\text{V}$  for our detectors. Principally a single supply (4.5V ... 16V) is also possible, for this version the TO39-housing of our single detectors is located on Reference potential (mostly U/2).

For customized detectors we can also integrate different operational amplifiers, which can be operated either with a very small supply voltage (single supply +2.2V) and isolated detector housing or with very supply high voltages and a high dynamic range (split supply  $\pm 13\text{V}$ ).

InfraTec can assure the availability of detectors with JFET source follower and CMOS-OpAmp for many years to come. The technical advantages will however accelerate the trend to use the current mode OpAmp detectors.

# Advanced Features of InfraTec Pyroelectric Detectors

## 2. Microphonic Effect in Pyroelectric Detectors

### 2.1. Basics

All pyroelectric crystals are inherently piezoelectric. This effect is seen readily in Quartz. When a pyroelectric detector is mechanically excited through shock or vibration, an unwanted signal is produced. This behavior is called a microphonic effect or vibration response.

The interaction of mechanical and electrical variables in piezoelectric crystals can be expressed in an open-circuit operation by a simplified equation for the electrical field strength  $E$  and its dependence on stress  $T$  as shown in table 1. Depending on the orientation of the stress, two basic effects can be distinguished: the transverse effect (along the chip edges) and the longitudinal effect (through the thickness).

	<b>Transverse Effect</b>	<b>Longitudinal Effect</b>
Model	$\vec{T} \perp \vec{E}$	$\vec{T} \parallel \vec{E}$
Open-circuit voltage	$u_{vib} = -\frac{d_{31}}{\epsilon_0 \epsilon_{T33}} \frac{\rho b h}{2} \tilde{a}$	$u_{vib} = -\frac{d_{33}}{\epsilon_0 \epsilon_{T33}} \frac{\rho h^2}{2} \tilde{a}$
Open-circuit voltage of a 30μm thick LiTaO <sub>3</sub> chip, 3mm sq. element size, acceleration 9.81m/s <sup>2</sup> (b=3mm, h=30μm, a=1g)	$u_{vib} = 25 \mu V$	$u_{vib} = 0.8 \mu V$

Table 1: Comparison of transverse and longitudinal effect on a square thin chip

If the stress  $T$  is applied into the plane of the chip and transverse to the electric field strength  $E$  one can use the transversal model. The stress is a linear function in the X direction and exhibits its maximum value at the bearing point and zero-crossing at the right border. The mean stress is half of the maximum stress  $T_{xx}$ . A lithium tantalate element with a square electrode of 3mm x3mm and thickness of 30 μm would produce an open-circuit vibration voltage of about 25 μV at 1g (9.81m/s<sup>2</sup>). If the acceleration acts longitudinal to the electrical field strength  $E$  and out of the plane of the chip the open-circuit vibration voltage per g is about 0.8 μV for a 30 μm thick lithium tantalate chip. This vibration voltage represents a limit for the reduction of the microphonic effect for a single element. Any further reduction could be achieved only by adding an anti-parallel / anti-serial compensating element.

### 2.2. Reduced microphonic voltage by “in-chip-compensation”

The simplest solution for reducing the stress caused by the transverse effect is the simultaneous clamping of the chip, both at the left and right borders. This results in tensile and compressive stress in the halves of the element and would counterbalance each other. A central fastening leads also to the compensation of stress. As shown in figure 1 the open-circuit vibration voltages are minimized by both the fastenings.

# Advanced Features of InfraTec Pyroelectric Detectors

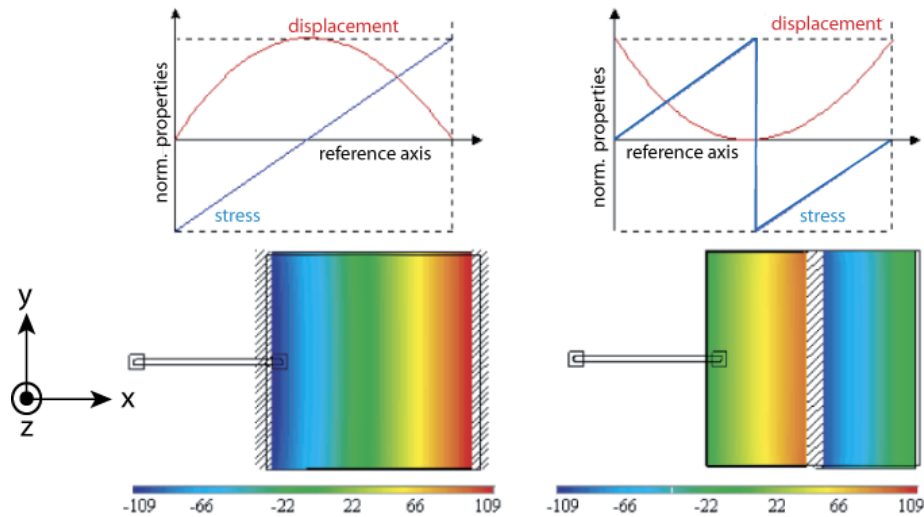

Fig. 1: Stress distribution on a double-sided (left), and center (right) clamped pyroelectric detector chip (3x3x0.03) mm<sup>3</sup> with acceleration in the X direction

The analytical description of the microphonic effect shows that the transverse effects are minimized by an outer symmetrical mounting, or a central mounting and that the longitudinal effect is much lower. However, stress overshoot around the mounting points is produced, when the acceleration is applied out-of-plane. In this case the simplified analytical description of the longitudinal effect does not provide proper results, since the chip structure and chip mounting varies significantly from the ideal configuration. In contrast to the ideal configuration, the arrangement and thickness of the electrodes is different. Furthermore, an additional absorption layer displaces the neutral stress line out of the center line. The influence of an acceleration out-of-plane could only be described accurately by a numerical analysis, for example by the simulation software ANSYS Multiphysics.

As shown in figure 2, the base for the numerical analysis is a chip holder. The chip holder consists of a base plate with a central column surrounded by four symmetrically arranged columns. The pyroelectric chip is assembled on the chip holder by adhesive bonding.

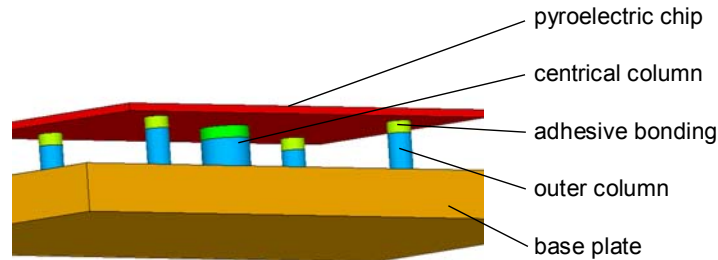

Fig. 2: Model of the assembly of chip holder and pyroelectric chip

In the plane of the pyroelectric chip the open-circuit vibration voltage is compensated by the symmetrical arrangement of all columns. If we look at the out-of-chip plane, the open-circuit vibration voltage is compensated by the arrangement of the outer surrounding columns in such a manner that convex and concave warpings are induced by mechanical excitation in the normal direction. These warpings produce tensile and compressive stress at one surface and the reversed at the opposite side of the pyroelectric chip as illustrated in figure 3. The positive and negative piezoelectric charges generated by the stress are compensated by the electrodes, which cover the top and the bottom sides. To achieve a stress

---

# Advanced Features of InfraTec Pyroelectric Detectors

---

compensation, the chip deformation can be optimized by modifying the arrangements of the mountings (see figure 4).

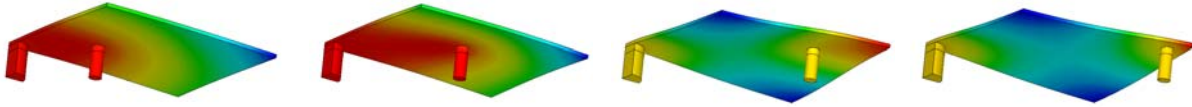

Fig. 3: Deformation and stress of a quarter of a pyroelectric chip assembled on a chip holder using different support positions along the chip diagonal

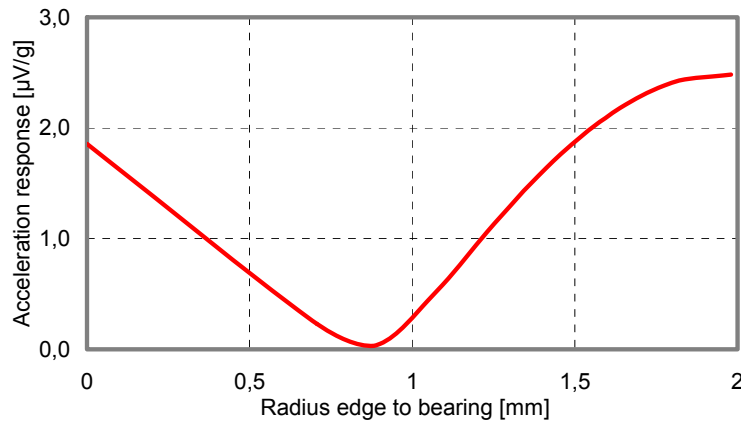

Fig. 4: Acceleration response of the chip shown in fig.3 as a function of the mounting point position

The stress distribution inside of a pyroelectric chip is also affected by the chip coating, technological parameters, as well as the elastic modulus of the adhesive by which the pyroelectric chip is bonded onto the chip holder. Nevertheless the statistics of sample measurements confirmed a good fitting of the test results and simulated values.

### 2.3. Microphonic effect at Voltage and Current mode operation

The operational mode of a pyroelectric detector and the frequency range affects the result of piezoelectricity at detector's output (see figure 5).

#### Voltage mode

The Open-circuit operation of a pyroelectric chip as described in the earlier BASICS section is given typically in voltage mode for frequencies higher than 0.5 Hz. The criteria for this is the electrical break point set by the product of chip capacity (30 ... 120 pF) and load resistor (5 ... 100 GOhm). In this frequency range the vibration or so called microphonic voltage at the detector output is identical with the open-circuit vibration voltage (see BASICS):

$$u'_{vib VM} = u_{vib} \quad (1)$$

A typical signal of a voltage mode detector is in the order of millivolts. A 100g acceleration (e.g. a shock) can produce a similar but disturbing signal of the mechanical vibration if its frequency fits the amplifier pass band.

# Advanced Features of InfraTec Pyroelectric Detectors

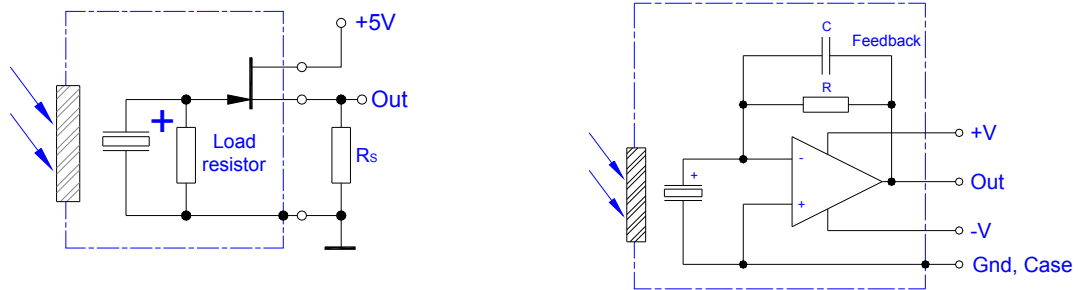

Fig. 5: Voltage mode operation (left) and current mode operation (right) of a pyroelectric detector

## Current mode

State-of-the-art pyroelectric detectors make use of the current mode (see figure 5) more and more. From the open-circuit vibration voltage  $u_{vib}$  the short-circuit current  $i_{vib}$  is derived, which **increases in** a linear manner with the frequency. The short-circuit current flows in a preamplifier and generates a signal voltage  $u'$  at the output:

$$\tilde{u}'_{vib} = i_{vib} R \frac{1}{[1 + (\omega\tau_E)^2]^{1/2}} \quad (2)$$

As in voltage mode operation the microphonic voltage at detector's output is constant for frequencies well above the electrical cut-off frequency. Because the electrical time constant in current mode is defined by the feedback components  $C$  and  $R$  (this time constant is clearly shorter) this frequency range starts only from some 10 Hz. In this frequency range the vibration voltage at the detector output is created by the open-circuit vibration voltage (see Basics) but amplified by the quotient of the capacitance of the pyroelectric chip and of the feedback capacitance:

$$u'_{vib\ CM} = u_{vib} C_P C_{fb}^{-1} \quad (3)$$

## Comparison

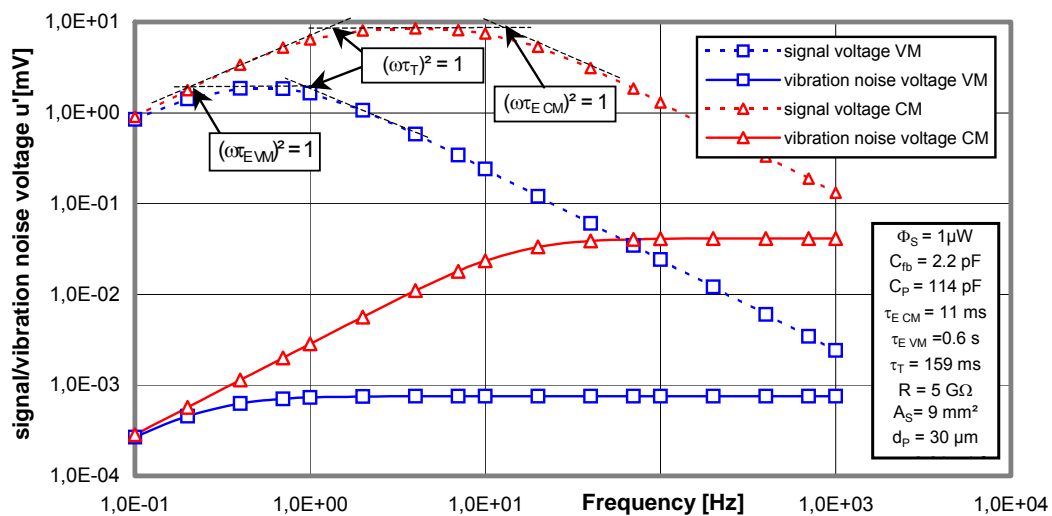

Fig. 6: Comparison of the signal voltage  $u'_s$  and of the vibration interference voltage  $u'_{vib z}$  (longitudinal effect) in voltage mode and current mode

# Advanced Features of InfraTec Pyroelectric Detectors

Figure 6 shows the frequency correlations with straight lines for the vibration voltage and dashed lines for signal voltage. The results are indicated with circles and squares for the current mode and the voltage mode respectively. Even if the vibration voltage behaves differently for current and voltage mode the ratio of signal to vibration voltage at a specific frequency (means the distance between the two red or the two blue lines in the diagram) is the same for current and voltage mode. There is no advantage from point of vibration responsivity by using current or voltage mode.

## 2.4. Introduction of the term “Microphonic-Equivalent Power (MEP)”

InfraTec introduced the Microphonic-Equivalent Power (MEP) for a simplified discussion:

$$MEP = \frac{R_{vib}}{R_v} \quad (4)$$

with

$$R_{vib} = \frac{u'_{vib}}{\tilde{a}} \quad (5)$$

The MEP is defined as the quotient of the vibration responsivity and voltage responsivity and indicates the incident radiation flux, required to generate an equivalent root-mean-square (RMS) signal voltage for a given vibration. It is expressed in the units of W/g (gravitational acceleration = 9.81m/s<sup>2</sup>). Table 2 summarizes vibration responsivity, voltage responsivity and MEP. Of course the MEP is more or less independent from the operation mode of the preamplifier. In the case of a standard detector, the vibration responsivity and hence the MEP strongly depend on the spatial direction of the applied vibration. In the case of microphonic reduced detectors (“low micro” type) with the novel chip holder, it is clearly demonstrated that the MEP value can be reduced to about 2 nW/g @ 10Hz in all three spatial directions.

Detector	Vibration Responsivity R <sub>vib</sub> (10Hz, 25°C) in μV/g			Voltage Responsivity R <sub>v</sub> (500K, 10Hz, 25°C) in V/W without window	Microphonic Equivalent Power MEP (10Hz, 25°C) in nW/g		
	x	y	z		x	y	z
LIE-502 (VM)	16	1,6	3,5	160	100	10	22
LIE-500 (CM)	550	55	120	5.500	100	100	22
LME-502 (VM)	0,5	0,5	0,4	160	3	3	2
LME-500 (CM)	65	65	50	22.000	3	3	2

Table 2: Vibration responsivity, voltage responsivity and microphonic-equivalent power of standard and “low micro” detectors

### Conclusion

There are three ways to reduce the influence of the piezoelectric behavior on pyroelectric detectors in customer’s sensor modules:

- Suppress mechanical vibrations as good as possible by pulse damper (smooth rubber, flexible cables). Please note that the elongation [mm] at a constant acceleration [m/s<sup>2</sup>] is frequency dependent. A sinusoidal acceleration of 1g = 9.81m/s<sup>2</sup> is the result of a peak-to-peak elongation of:

70cm at 1Hz	7mm at 10Hz	70μm at 100Hz	0.7μm at 1kHz
-------------	-------------	---------------	---------------

In a compact sensor module a mechanical damping can only be realized for frequencies higher than 100Hz.

## Advanced Features of InfraTec Pyroelectric Detectors

- Limit the electrical pass band of the amplifier stages especially at the high frequency side by a steep low pass.
- Compensation of the microphonic voltage by sophisticated mounting of the pyroelectric chip.

InfraTec offers a variety of pyroelectric detectors of voltage mode (VM) or current mode (CM) operation with a reduced vibration response (so called “low micro”) based on InfraTec’s patented chip mounting technology. The reduction of the microphonic voltage is in the order of a twentieth (5%) of a conventional pyroelectric detector. Figure 7 shows their typical frequency response. Please note that the differing vibration voltage of the CMOS OpAmp detector series LME-351, -341 and -335 caused on a differing gain. LME-335 offers the highest responsivity (90,000 V/W @ 10Hz).

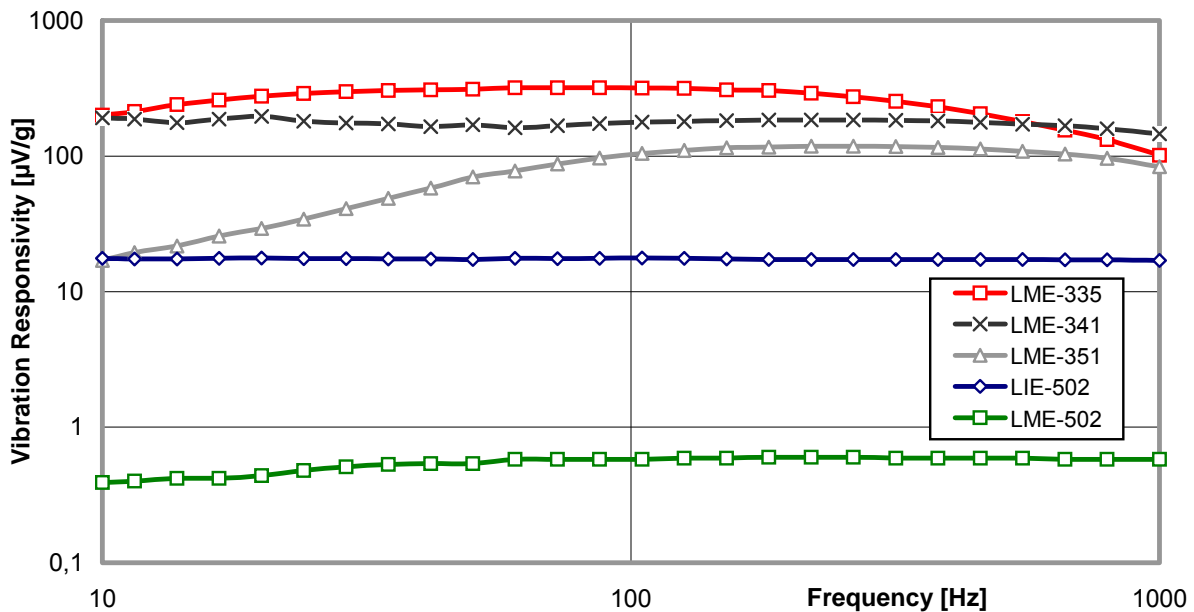

Fig. 7: Test results of microphonic effect

LME-502 (VM, 3x3mm<sup>2</sup>, “low micro”), LIE-502 (VM, 3x3mm<sup>2</sup>, conventional),

LME-351 (CM, 2x2mm<sup>2</sup>, “low micro”, 5GΩ/0.2pF), LME-341 (CM, 2x2mm<sup>2</sup>, “low micro”, 24GΩ/0.2pF),

LME-335 (CM, 2x2mm<sup>2</sup>, “low micro”, 100GΩ/0.2pF)

InfraTec’s “low micro” technology is available for single element detectors such as LME-316 (VM) or LME-345 (CM) and multi-color detectors such as LMM-244 with an element size of 2x2 or 3x3 mm<sup>2</sup>. These detectors can be identified at the part description by a “M” in the second digit (LME instead of LIE or LMM instead of LIM).

---

# Advanced Features of InfraTec Pyroelectric Detectors

---

## 3. Beamsplitter Detectors - even for the narrowest signal beams

The principle of the multi-color detector with integrated beamsplitter is shown in the following picture. The IR radiation entering through the aperture stop is divided by a beamsplitter in two or four parts (4 channel pictured). Each of the partial beams goes through an IR filter and then hits a pyroelectric detector chip. This design works well with single narrow-beam sources, or in situations where contamination (dust, insects) in the light path could be an issue.

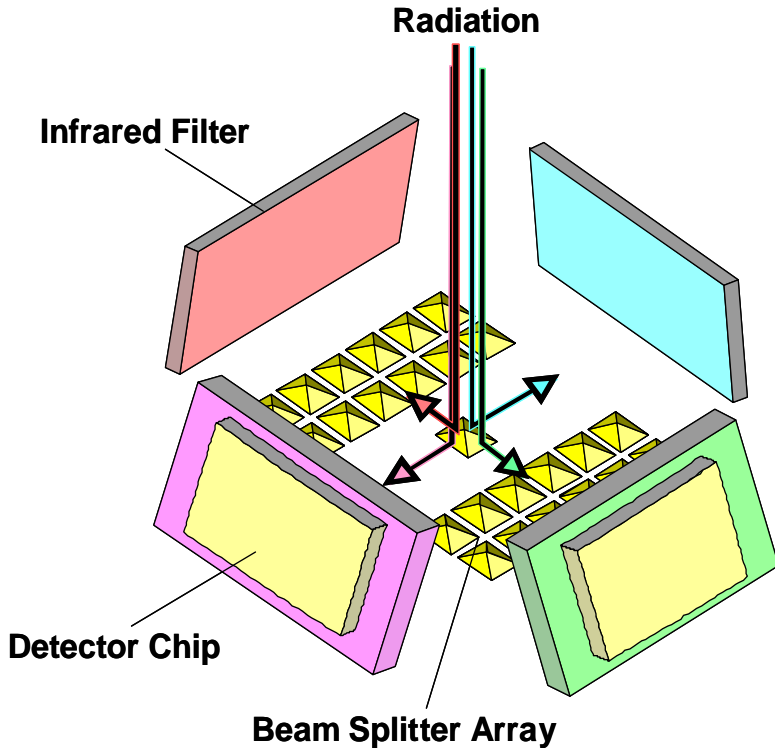

Fig. 1: Principle of reflective beamsplitting

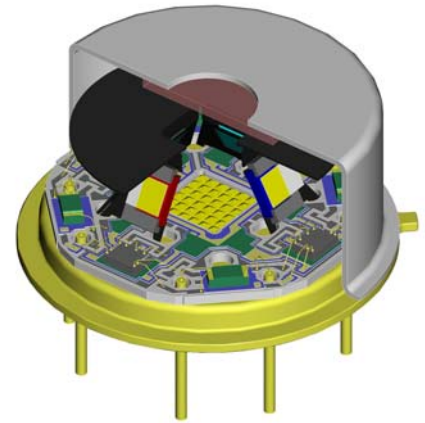

Fig. 2: 3-D Design LIM-054

### 3.1. General design

The beamsplitters are made of gold plated microstructures for the two and four channel devices to achieve a homogeneous distribution of the radiance. The filters are mounted at a certain angle to obtain a normal incidence of the radiation. This configuration avoids drifts in the filter transmission curves to shorter wavelengths and the influence of the opposite filter (reflections).

In addition to four channel beamsplitter detectors using four-sided micro pyramids, InfraTec has also developed two channel detectors based on micro V-grooves. In the following figure SEM images of two and four channel beamsplitters are shown. The V-grooves pitch is 100  $\mu\text{m}$  and the pyramids are 50  $\mu\text{m}$ , with the tilt angle of the filters and detectors set at 30°.

# Advanced Features of InfraTec Pyroelectric Detectors

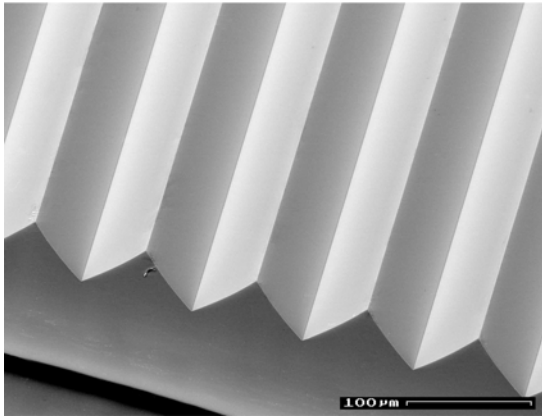

Fig. 3: Micro groove (2-channel)

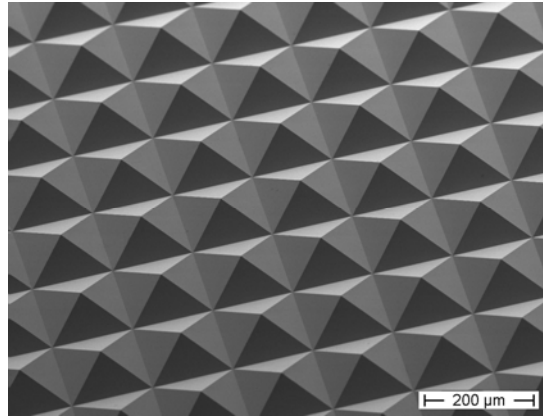

Fig. 4: Micro pyramids (4-channel)

## 3.2. Comparison to other multi channel detectors

The beamsplitter detector has a single aperture stop compared to other multi channel detectors. It is possible to use a gas cell with a smaller diameter reducing the gas volume. A smaller gas volume reduces the size of the sensor module and accelerates the gas exchange. Also, the signal ratio of all channels is independent from aging, mechanical shift or pollution processes among one another.

The **multi-color** detectors should be used for the analysis of gas mixtures with few known gases. Typical examples for a successful application are anesthetic gas monitors and the pulmonary function testing. **Variable color** detectors allow a more flexible operation of the analyzer enabling the detection of adjoining or overlapping absorption bands. So far the measurement of single gases like ethanol and carbon dioxide as well as gas mixtures of methane, propane and anesthetic gases have been tested. In the following table characteristics of the multi- and variable color detectors are summarized.

Detector Specification	Multi-color	Multi-color	Variable color
Principal	Individual Windows	Beamsplitter	Tunable Fabry-Perot Filter
Filtering	Parallel	Parallel	Serial
Area to be illuminated	Ø 9.5mm	Ø 2.5mm	Ø 1.9mm
Spectral Range	(2...25) μm	(2...25) μm	(3.0...4.1) μm and (3.9...4.8) μm
Current Mode	Yes	Yes	Yes
Voltage Mode	Yes	Yes	No
Thermal Compensation	Yes	No	Yes

# Advanced Features of InfraTec Pyroelectric Detectors

## 4. Basics and Application of Variable Color Products

The key element of InfraTec's variable color products is a silicon micro machined tunable narrow bandpass filter, which is fully integrated inside the detector housing. Applying a control voltage to the filter allows it to freely select the wavelength within a certain spectral range or to sequentially measure a continuous spectrum. This design is very different from detectors with fixed filter characteristics and enables the customer to realize a low resolving and low cost spectrometer.

The variable color product group includes the **LFP-3041L-337** and **LFP-3950L-337** which differ in the wavelength range they each cover. The pyroelectric detector used is similar to the standard **LME-337** device.

### 4.1. Fabry-Perot filter (FPF)

The filter-detector assembly (see Figure 1) is based on the well-known Fabry-Perot Interferometer (FPI). Two flat and partially transmitting mirrors with reflectance  $R$  are arranged in parallel at a distance  $d$ , forming an optical gap. Multiple-beam interference is created inside the gap and thus only radiation can be transmitted, which satisfies the resonance condition according to equation (1).

One of the mirrors is suspended by springs so that the distance  $d$  can be decreased by applying a control voltage. As the resonance condition changes so does the wavelength of the transmitted radiation.

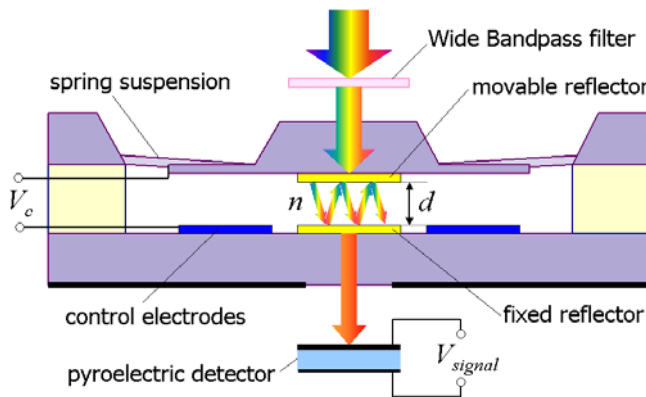

$$\lambda_m = \frac{2 n d \cos \beta}{m} \quad (1)$$

- $n$  refractive index inside the gap
- $\beta$  angle of incidence ( $\beta = 0$  in fig.1)
- $m$  interference order
- $d$  modulating distance

Fig. 1: Configuration and operation principle of the FPF with an integrated pyroelectric detector

The **transmittance spectrum**  $T(\lambda)$  of the FPF (see Figure 2) is described by the Airy-Function. Given that  $n = 1$  (air inside the gap) and  $\beta = 0$  (vertical incidence), this results in:

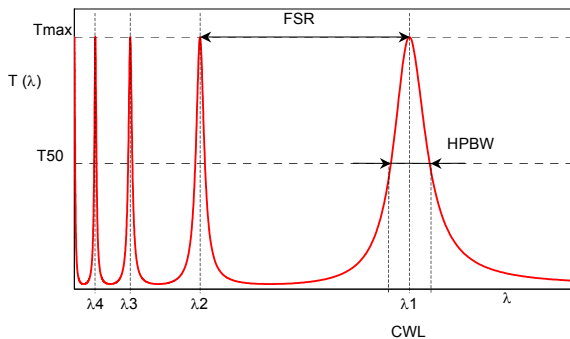

$$T(\lambda) = \frac{T_{\max}}{1 + F \sin^2(2\pi d/\lambda)} \quad (2)$$

with the F-value:

$$F = \frac{4R}{(1 - R)^2} \quad (3)$$

Fig. 2: Transmittance spectrum of a FPF

# Advanced Features of InfraTec Pyroelectric Detectors

The characteristic parameters of a FPF can be derived from the previous equations. In our case, the first interference order is used ( $m = 1$ ), while the higher orders are blocked by means of an additional bandpass filter.

**The center wavelength (CWL)** of the filter corresponds to the resonant wavelength in theory. In practice the **CWL** is measured as the mean value of the two **half-power-points ( $T_{50}$ )**.

The **half-power bandwidth (HPBW)** is the decisive factor for the spectral resolution:

$$HPBW = 2d \left( \frac{1-R}{\pi\sqrt{R}} \right) \quad (4)$$

The spectral distance of two adjacent interference peaks limits the maximum usable tuning range. This is referred to as the **free spectral range (FSR)**.

The ratio of the tuning range to the bandwidth (in the frequency or wavenumber domain) is given as the **Finesse ( $\tilde{F}_R$ )**, which is the figure of merit of a FPF:

$$\tilde{F}_R = \frac{FSR}{HPBW} = \frac{\pi\sqrt{R}}{1-R} = \pi \frac{\sqrt{F}}{2} \quad (5)$$

## 4.2. Optical Considerations

In the real world there are some practical constraints, so it's necessary to complete the previous statements and equations:

The mirrors of the FPI are made from dielectric layer stacks (Bragg reflectors). This limits the width of the reflective band and thus the usable spectral tuning range to about  $1.3\mu\text{m}$ . Bragg reflectors have a distinct phase shift, which actually has to be considered in the equations stated above. This causes an increase of the mechanical adjustment travel  $\Delta d$ :

$$\Delta CWL = k \cdot 2\Delta d \quad (k < 1 \text{ phase correction}) \quad (6)$$

An inclined but collimated beam results in a negative drift of the CWL (see figure 3 left). The most common case is an uncollimated beam with a certain angle of divergence and intensity profile. The resulting transmittance spectrum can be seen as the superposition of collimated ray-beams with different angles of incidence and intensities. The superimposed spectrum has a broader HPBW and the CWL at slightly lower wavelengths (see figure 3 right).

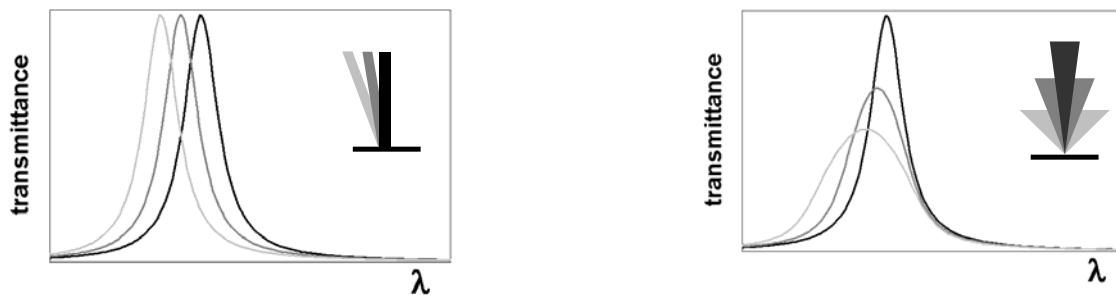

Fig. 3: Influence of angle shift and divergence angle on bandwidth and peak transmittance of a FPF

# Advanced Features of InfraTec Pyroelectric Detectors

Beam divergence can be minimized by using a light source with collimated output or by means of an additional prefixed aperture (see figure 4 left). If the desire is to maximize the optical throughput, then focusing optics can be used, but larger divergence angles will be a side effect (see figure 4 right).

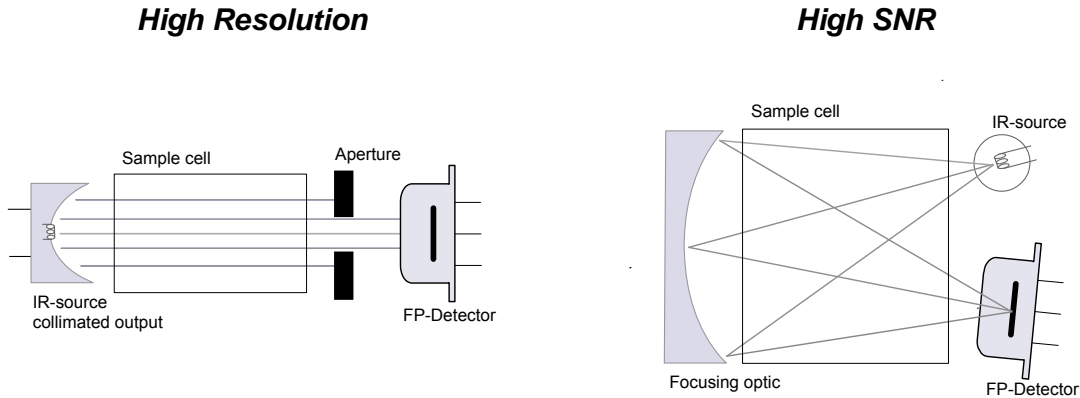

Fig. 4: Possible optimizations for the optical design of a microspectrometer with FPF detector

**left set up:** corresponds with an illumination by a parallel beam; **right set up:** corresponds with a high angle of incidence (AOI)

The performance of such a system strongly depends on the optical conditions. A compromise between spectral resolution and **signal-to-noise ratio (SNR)** for the particular application needs to be found. This principle is in fact valid for all spectrometric applications. Figure 5 shows the correlation of the achievable SNR with a given spectral resolution, measured with two tested measurement set ups according to figure 4. Please note that a parallel beam  $\varnothing 1\text{mm}$  offers the highest spectral resolution but only 3% of the intensity and thus the resulting low detector signal voltage compared to an illumination using f/1.4 optics.

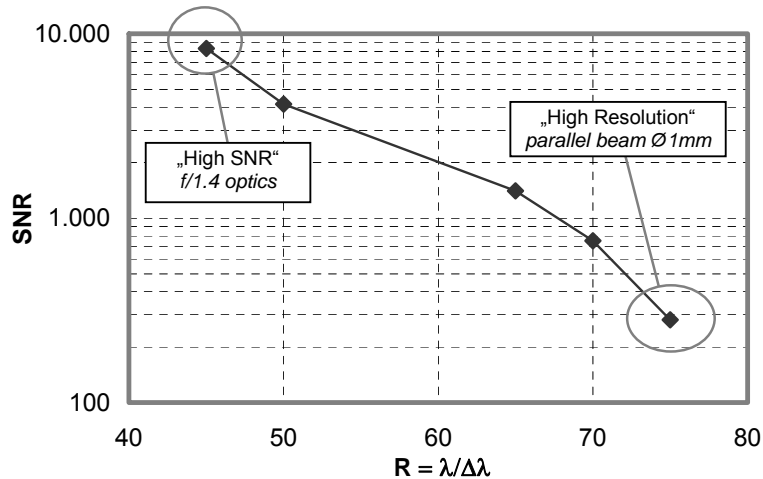

Fig. 5: Measurements of the SNR vs. spectral resolution

LFP-3041-337 with a modulated IR source at 10Hz, **left end point:** Illumination at high angle of incidence (AOI) using f/1.4 optics **right end point:** Illumination with a parallel beam  $\varnothing 1\text{mm}$

# Advanced Features of InfraTec Pyroelectric Detectors

Tuning the CWL of the FPF results in a variation of the HPBW and the peak transmission within certain limits, too. The additionally implemented broad band pass and the pyroelectric detector element also show some spectral characteristics. The spectral response of the detector is therefore a superposition of different fractions, but has to be considered as a whole in the application. It is stated as the relative spectral response, referring to a “black” reference detector with a flat spectral response (see figure 6).

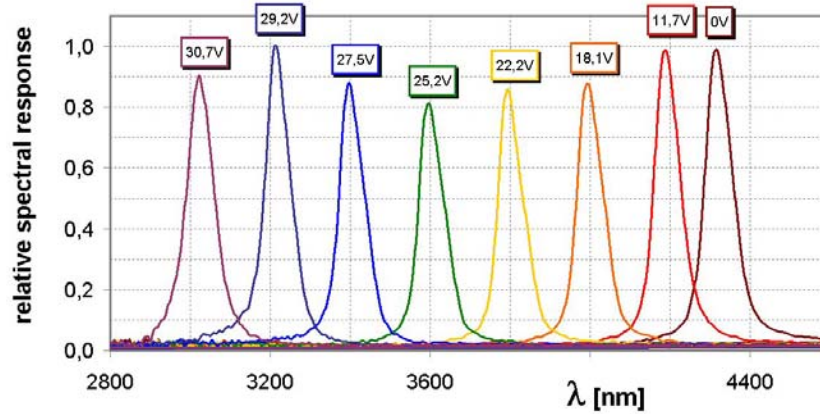

Fig. 6: Relative spectral response of a FPF detector LFP-3041L-337 at several tuning voltages

### 4.3. Filter operation

The filter is activated electrostatically. The driving electrode ( $V_{c+}$ ) is arranged at the fixed reflector carrier, the movable reflector carrier acts as an electrode with the fixed reference potential  $V_{cref}$  (see figure 8). Applying a tuning voltage  $V_c = V_{c+} - V_{cref}$  results in an electrostatic force  $F_{el}$  decreasing the electrode gap  $d_{el}$ .

$$F_{el} = \frac{\epsilon_0 A_{el} V_c^2}{2d_{el}^2} \quad (7)$$

With this the drive capacity is increased from  $\approx 50 pF$  in passive state ( $V_c=0V$ ) to  $\approx 65 pF$  at maximum modulation. Additionally a parasitic parallel capacity of 1nF needs to be considered. In the case of steady state, a typical non-linear characteristic curve is received (see figure 7).

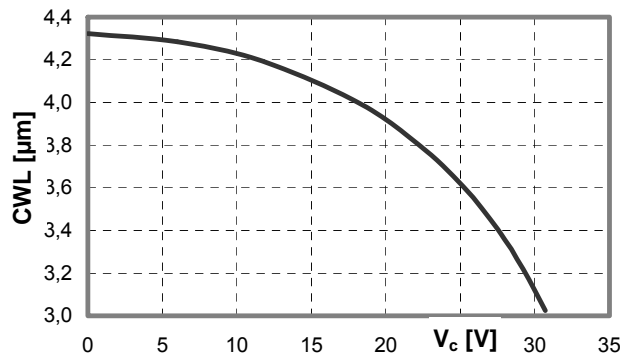

Fig. 7: Typical steady-state control characteristic for LFP-3041L-337

# Advanced Features of InfraTec Pyroelectric Detectors

The polarity of the control voltage needs to be maintained, even as in equation (7) this doesn't seem to be necessary.

The circuit points *Shield*, *Substrate* and  $V_{cref}$  should be on the same stabilized, low-impedance potential. Spikes, a ripple voltage and other interfering signals at these circuit points can cause cross talk to the pyroelectric detector components by parasitic capacitances.

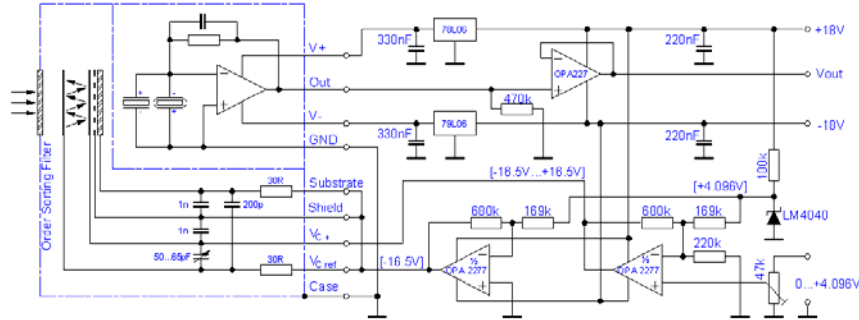

Fig. 8: Example of circuitry for detector and filter operation ( $\pm 18V$  bipolar supply)

The movable reflector of the FPI is a mass-spring-system, which is progressively damped by the air cushion in the gap. The non linear fraction in equation (7) effects a decreasing stiffness of the whole system with increasing modulation, i.e. smaller gap. This behavior leads to several effects:

The filter exhibits an acceleration sensitivity but vibrations will be damped due to the mechanical low pass characteristic. In steady state a dependence of the CWL on the position related to the gravitation field is observed (see Figure 9). Both effects are dependent on the actual mirror position.

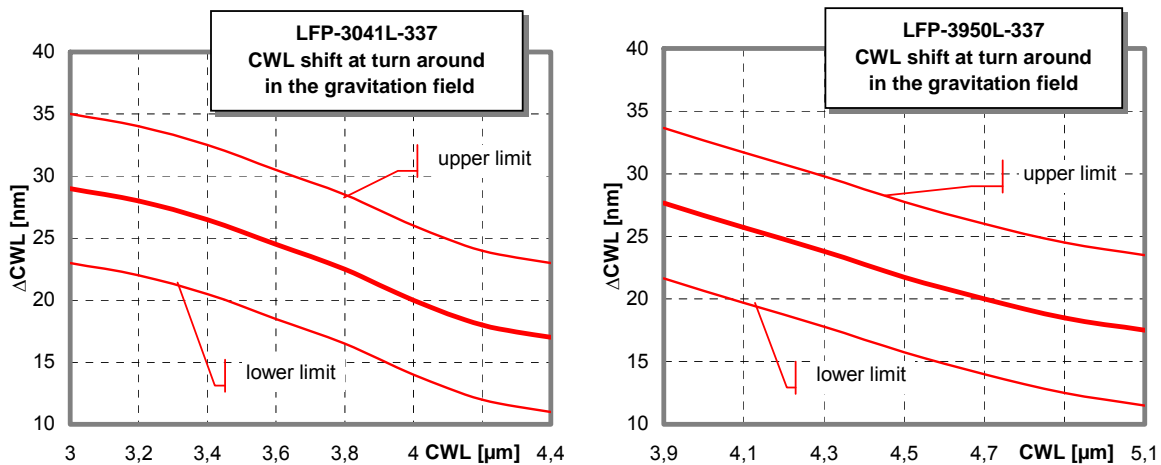

Fig. 9 Position dependency of the CWL, typical values and tolerance zones of LFP-3041L-337 (left) and LFP-3950L-337 (right)

- The filter shows a stability limit at the so-called pull-in point. This should never be exceeded during operation, otherwise the filter could be damaged. As a guideline for steady state can be given: Don't exceed the control voltage for maximum modulation (e.g. CWL=3000nm for LFP3041L-337) for more than 0.5 volts. This is an individual value for each device.

# Advanced Features of InfraTec Pyroelectric Detectors

- The transient response of the filter is non-linear. For shorter wavelengths the system reacts slower, because the total stiffness of the system is low and the air damping is high. The stated settling time (see figure 10) is defined as the necessary time to achieve the final value of the CWL with a tolerance of  $\pm 1$  nm for a control voltage step.

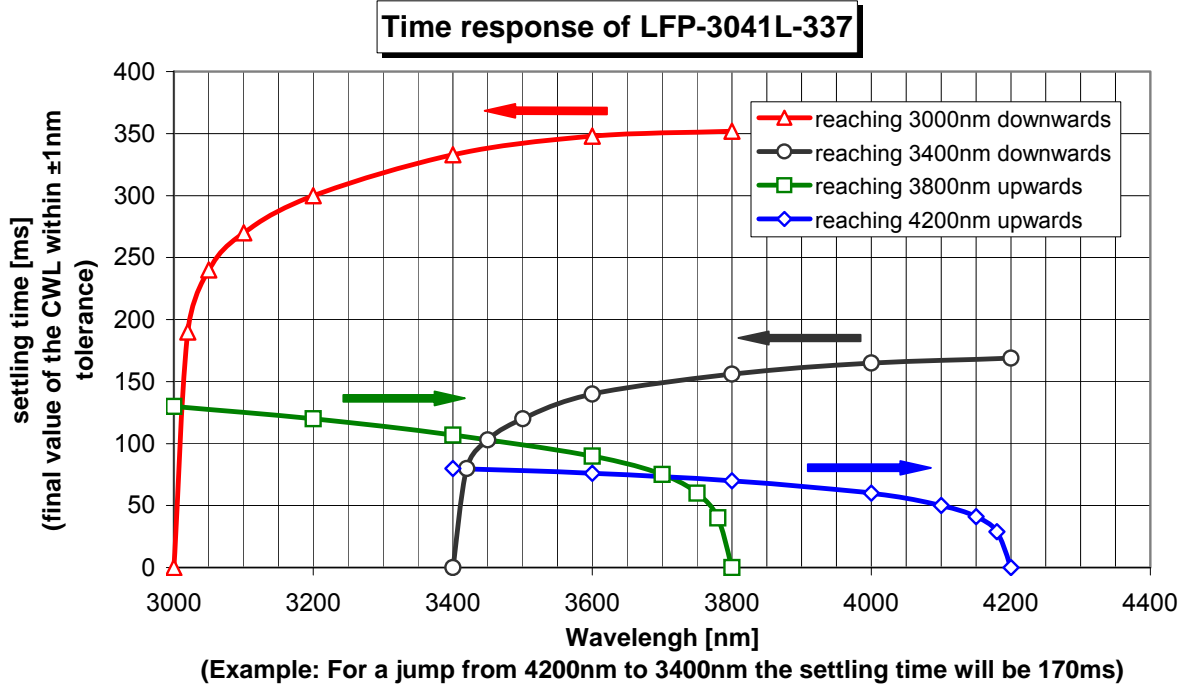

Fig. 10: Transient response for LFP-3041L-337, typical values

- The FP filter also shows a significant temperature dependency. As a temperature change mainly results in a mechanical detuning of the filter, the correlation between HPBW and CWL remains unchanged.

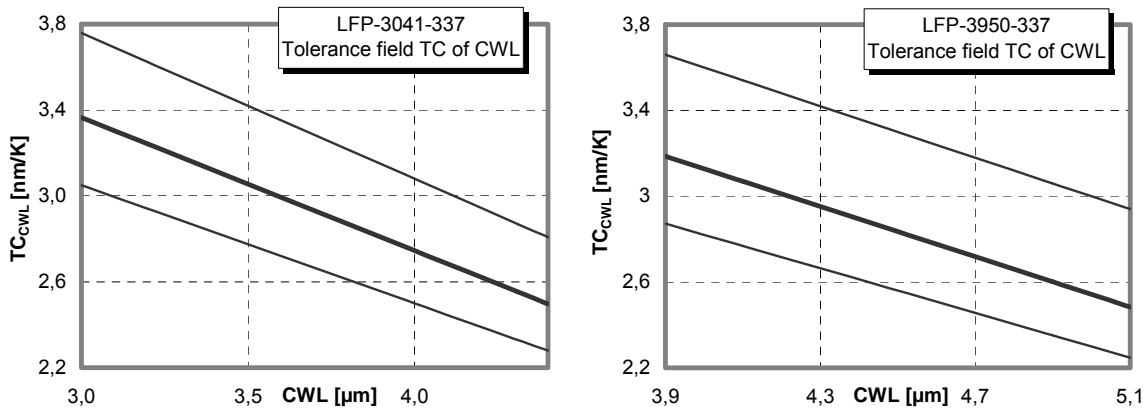

Fig. 11: Temperature coefficients of the CWL, typical values and tolerances for LFP-3041L-337 (left) and LFP-3950L-337 (right)

---

# Advanced Features of InfraTec Pyroelectric Detectors

---

## 4.4. Operation modes and measurement methods

The capabilities of FPF (so called variable color) detectors are numerous. Depending on the measurement task and operation mode, different advantages compared to conventional single or multi channel detectors with fixed NBP filters can be found.

Hereafter three different operation modes will be explained in detail:

### Sequence of channels

In the most simple case several fixed detector channels shall be substituted by a tunable detector. The filter is sequentially adjusted to the individual spectral channels. Beside the obvious advantage of the flexibility and expandability in the channel choice (in the region (3...5)  $\mu\text{m}$ ) additional advantages may be achieved:

- Simple multi channel detectors have separated apertures, which yield to the well known issues regarding non-uniform illumination, long-term stability, source drifting, pollution, etc. The variable color detectors don't show these problems due to their principal design and singular light path.
- Detectors with an internal beamsplitter also have a common aperture, but each channel is getting only a fraction of the whole radiant power. Applying the sequential measurement we can always use the whole incident radiant power. For four different channels and comparable conditions regarding aperture size and filter bandwidth theoretically a duplication of the SNR can be reached.

### Step scan

The method described above can still be expanded in such a way that continuous spectra can be obtained. The required acquisition time for the mapping of a spectrum depends on the following facts:

1. Number of measuring points (wavelength range, step size):  
To get a continuous spectrum it must be scanned at minimum with a step size which corresponds to the half filter bandwidth (sampling theorem). Moderate oversampling can be useful. The reasonable step size is in the range (10...50) nm.
2. Recordings of the measuring points (modulation frequency, integration time):  
These parameters define the SNR. Beside the detector properties and the applied analysis methods, the radiant power, modulation depth of the IR source and the design of the measuring section are crucial.

### Settling time of the filter:

The actual settling time of the filter depends on the wavelength as described earlier. It should therefore be implemented variably to achieve an optimum of speed.

---

# Advanced Features of InfraTec Pyroelectric Detectors

---

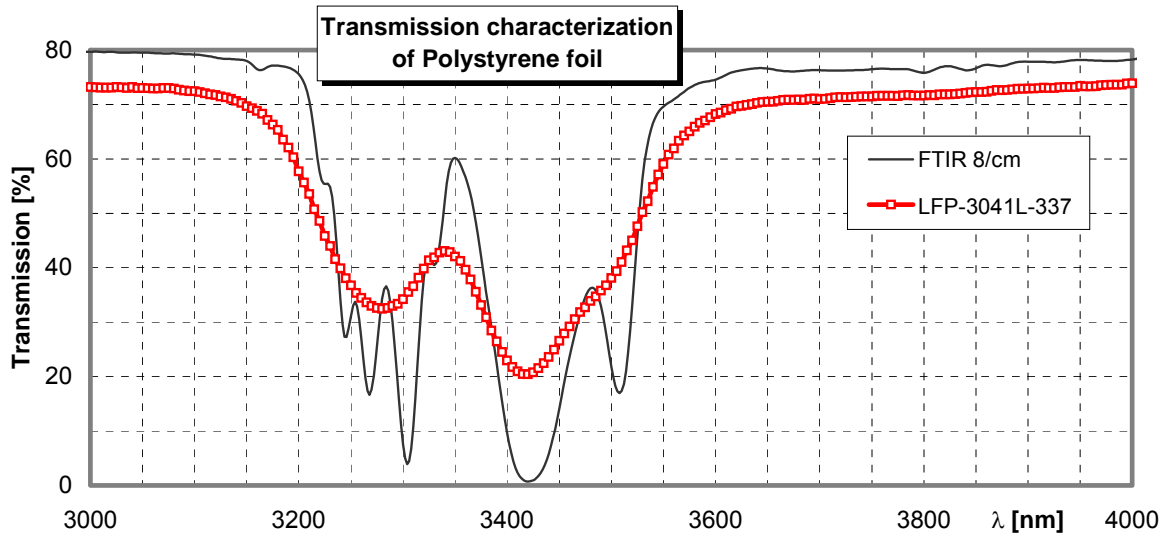

Fig. 12: Measurement example for the step scan mode (Polystyrene foil)  
LFP-3041L-337: spectral resolution  $R=65$ ;  $SNR \approx 1000:1$ ; 100 data points; acquisition time 10s

## Continuous scan

By using a pyroelectric detector only modulated radiation can be analyzed. Normally this is realized by mechanical chopping or electrical modulation of the IR source. If the filter is however continuously scanned the spectral information can be used directly for the modulation. The filter is actuated dynamically in this case.

This particular operation mode has principally the potential to accelerate the recordings of spectra remarkably. The earlier mentioned non-linear effects during dynamic operation however need to be considered separately. In most cases it is not correct to consider the filter as a linear system with low pass behavior even in a limited operation range.

Two basic approaches are possible for a dynamic operation:

- Presetting of voltage characteristics  $V_c(t)$  for filter modulation (sinusoidal, ramp or similar...) and
  - Detection of the resulting characteristics of the CWL by an adequate calibration for example with wavelength standards (e. g. NBP filters) or
  - Evaluation of the detector signal with dedicated software algorithms (chemometric techniques)
- Presetting of a designated progression of the CWL(t) and determination of the compatible voltage characteristic  $V_c(t)$  for example with wavelength standards

---

# Advanced Features of InfraTec Pyroelectric Detectors

---

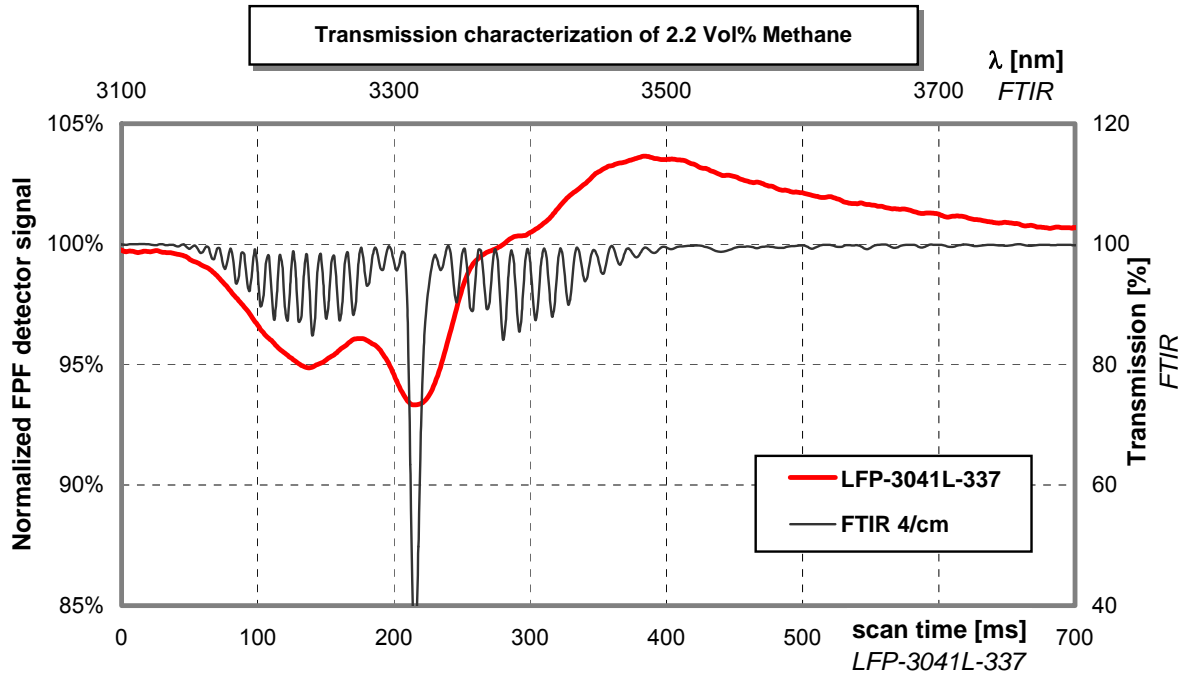

Fig. 13: Measurement example for the continuous scan mode with dynamic filter tuning (Methane)

Figure 13 gives an example for the dynamic operation. The source is working in DC operation, while the filter goes through the desired wavelength range. Except for the DC-portion, the whole spectral information is contained in the generated detector signal. The actuation and analysis has to include both the dynamic properties of the filter and the detector.

## 4.5. Summary

With the extension of our product range by variable color detectors additional technologies are available for our customers. All types of our multi-spectral detectors are complementing one another:

- Conventional dual and quad channel detectors can be used in competitive volume applications
- Our dual and quad channel beamsplitter detectors with one aperture are used as long term stable and very accurate measuring modules for different spectral channels
- Variable color detectors with a high SNR allow a more flexible operation of the analyzer enabling for example the detection of adjoining or overlapping absorption bands. They are also of interest for applications, where more than 4 spectral channels shall be scanned within a short time frame.