

## LIM-114-#

## pyroelectric multispectral detector

### Description:

quad channel; TO8 housing; medium chip size; JFET; voltage mode;

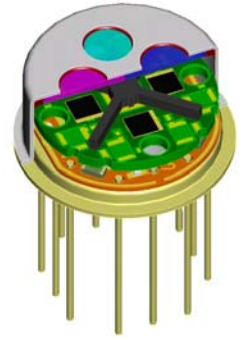

### HOUSING:

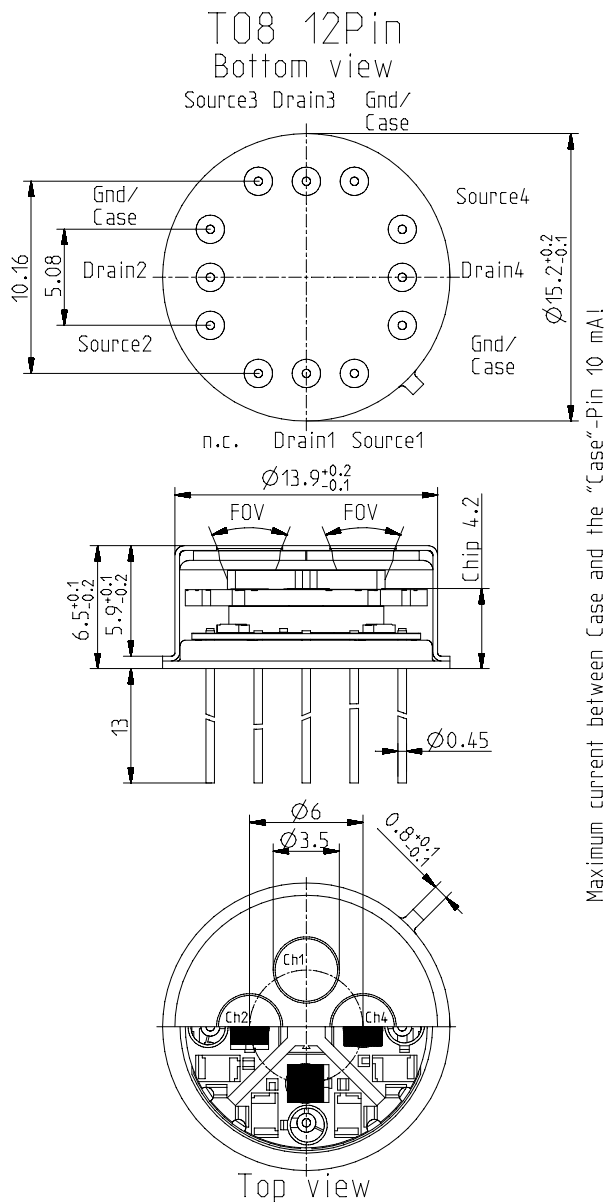

### PIN ASSIGNMENT:

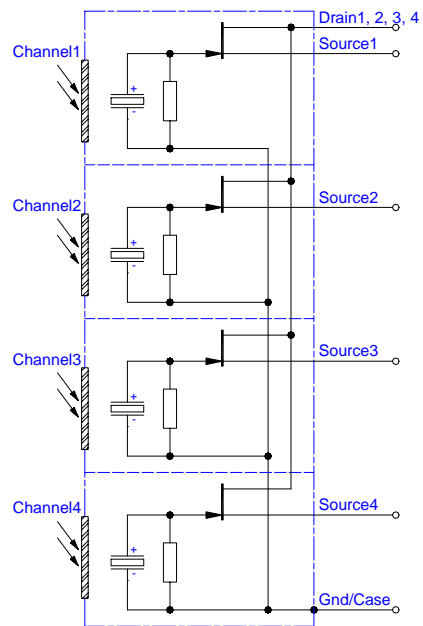

### FREQUENCY RESPONSE:

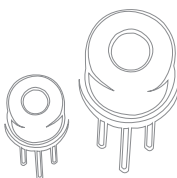
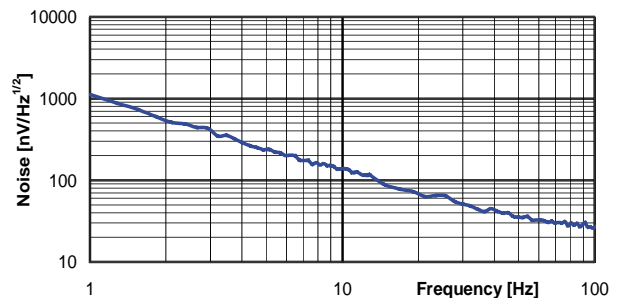
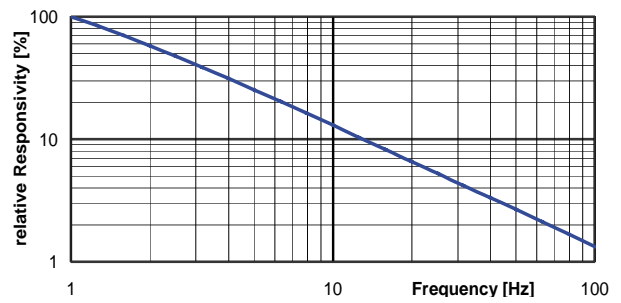

## LIM-114-#

## pyroelectric multispectral detector

### TEST CIRCUIT:

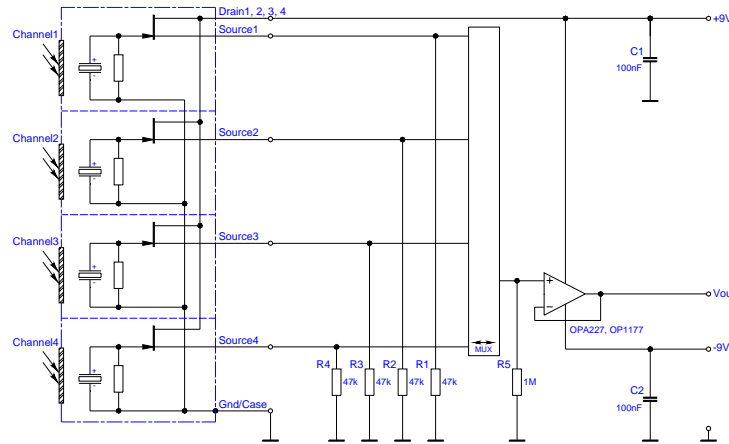

### PARAMETERS:

Aperture size	nom	ø9.5 mm, single channel ø3.5 mm
Element size / type	nom	2.0x2.0 mm <sup>2</sup> lithium-tantalate with black layer
Thermal time constant	typ	100 ms
Electrical time constant	typ	5 s
Polarity	nom	positive signal by positive IR flux change
Voltage responsivity (rms) {500K, 10 Hz, 25 °C, without window}	min	300 V/W
Noise density (rms) {10 Hz, BW 1 Hz, 25 °C}	max	150 nV/(sqrt[Hz])
Detectivity {500K, 10 Hz, 1 Hz, 25 °C, without window}	min	4.2E+08 cm(sqrt[Hz])/W
Offset voltage {opt. Drain current = 10 ... 100µA}	nom	0.4 ... 1.5 V
Drain source voltage	max	18 V
Operating / Storage temperature	nom	-25 ... +85°C
IR window		Combinations of all InfraTec standard narrow band pass filters are available. Customized filters upon request.
Filter sizes	nom	rectangular filters: (4.20 x 4.20) mm ±0.1 mm circular filters: not applicable standard thickness: 0.50 mm +0.2/-0.1 mm thickness range 0.70 ... 1.10 mm on request
Field of View	min	CaF <sub>2</sub> or BaF <sub>2</sub> ; 0.4 mm thick: not applicable Silicon substrate; 0.5 mm thick: 40°