

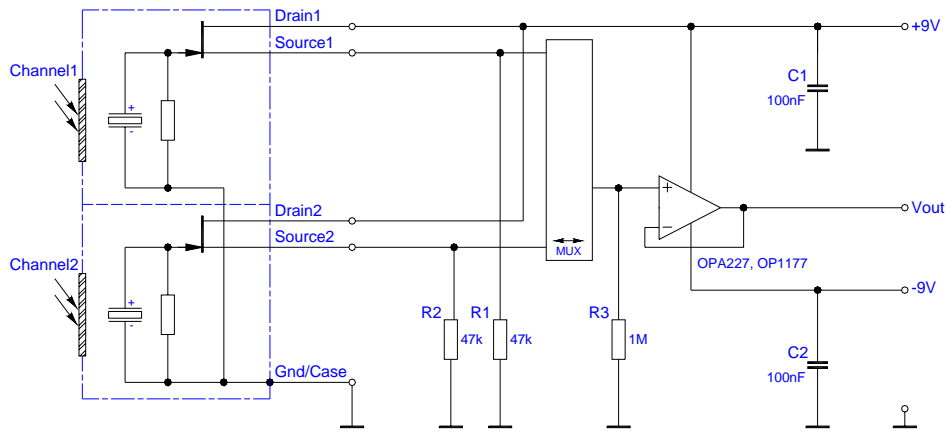

## LIM-012-#

## pyroelectric multispectral detector

### TEST CIRCUIT:



### PARAMETERS:

Aperture size	nom	ø2.5 mm
Element size / type	nom	2.2x1.3 mm <sup>2</sup> lithium-tantalate with black layer
Beamsplitter	nom	array of micro grooves
Thermal time constant	typ	250 ms
Electrical time constant	typ	5 s
Polarity	nom	positive signal by positive IR flux change
Voltage responsivity (rms) {500K, 10 Hz, 25 °C, without window}	min	140 V/W
Noise density (rms) {10 Hz, BW 1 Hz, 25 °C}	max	200 nV/(sqrt[Hz])
Detectivity {500K, 10 Hz, 1 Hz, 25 °C, without window}	min	1.6E+08 cm(sqrt[Hz])/W
Offset voltage {opt. Drain current = 10 ... 100µA}	nom	0.4 ... 1.5 V
Drain source voltage	max	18 V
Operating / Storage temperature	nom	-25 ... +85°C
IR window		Combinations of all InfraTec standard narrow band pass filters are available. Customized filters upon request.
Filter sizes	nom	rectangular filters: (2.70+0/-0.1 x 2.00+0.05/-0.1)mm circular filters: not applicable standard thickness: 0.50 mm +0.2/-0.1 mm
Aperture window		Selected by manufacturer for best channel filter matching
Aperture window sizes	nom	rectangular filters: (5.25+0/-0.05 x 5.25+0/-0.05)mm circular filters: ø6.5 mm ±0.1 mm standard thickness: 0.50 mm +0.2/-0.1 mm thickness range 0.70 ... 1.10 mm on request
Field of View	min	Maximum angle of incidence shall be ±7° otherwise internal reflexions may modify the channel ratio!